

**NOTES:**

- 1.) Post size depends on fence height and wind loads. See *MONTAGE PLUS™* specification for post sizing chart.
- 2.) Forth rail optional.
- 3.) 7' & 8' Heights will require a 14ga Picket & 14ga Post

**BX118 FLAT MOUNT END BRACKET**

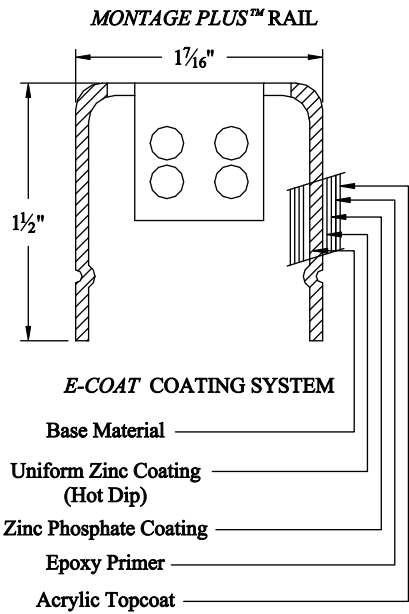
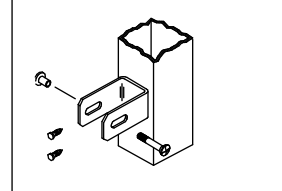

**PROFUSION™ WELDING PROCESS**

No exposed welds,  
Good Neighbor profile - Same  
appearance on both sides

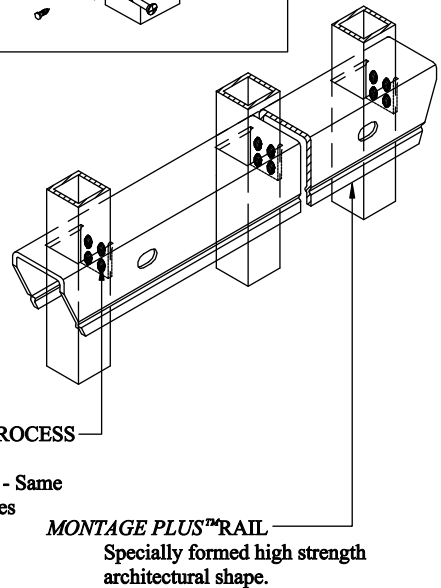

**COMMERCIAL STRENGTH WELDED STEEL PANEL  
PRE-ASSEMBLED**

Title: <b>MONTAGE COMMERCIAL INVINCIBLE 3/4-RAIL</b>			
DR: CI	SH . 1 of 1	SCALE: DO NOT SCALE	
CK: ME	Date 7/20/09	REV: d	



**AMERISTAR®**

1555 N. Mingo  
Tulsa, OK 74116  
1-888-333-3422  
www.ameristarfence.com