

TYPICAL 5 ROW
TOP PLAN

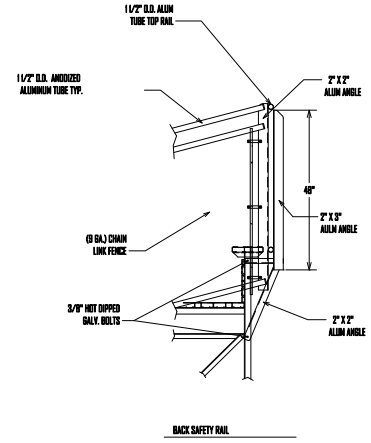

BACK SAFETY RAIL

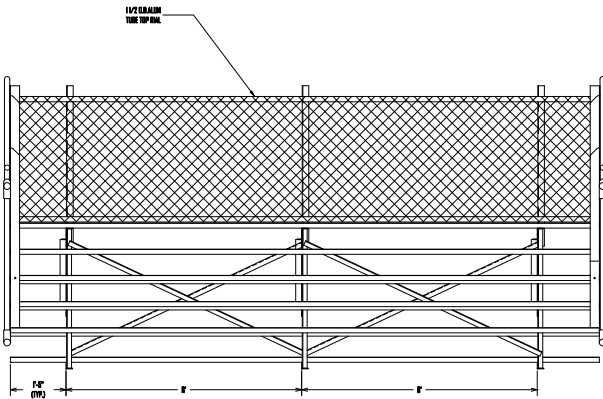

TYPICAL 5 ROW
FRONT ELEVATION

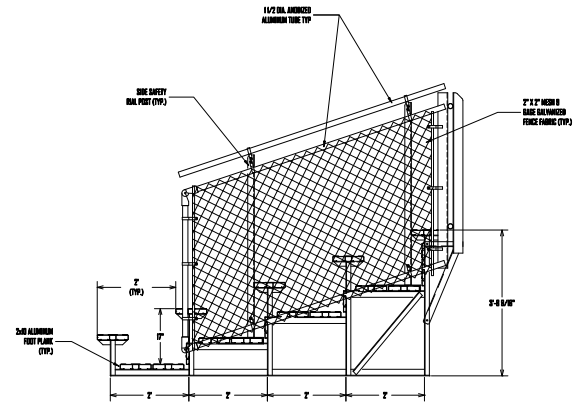

TYPICAL 5 ROW
SIDE ELEVATION

APPROVALS	DATE	BLEACHERS INTERNATIONAL			
DRAWN WJS	08/04/00				
CHKD		P.O. BOX 718 • Strasburg Colorado 80858-0718			
ENG		Phone: (303) 622-8528 • Fax: (303) 622-8524			
Drawing Description:		BLEACHERS STANDARD 5 ROW BLEACHER DETAILS			
THIS DOCUMENT CONTAINS PROPRIETARY INFORMATION AND SHALL NOT BE REPRODUCED OR DISCLOSED WITHOUT WRITTEN PERMISSION FROM BLEACHERS INTERNATIONAL. VIOLATION IS SUBJECT TO LEGAL ACTION OR IMPACT IS STRONGLY PROHIBITED.		DO NOT SCALE THIS DRAWING	SIZE D	SCALE NTS	SHEET 2 OF 2