

BLOCKING NOTE

PLACE SOLID BLOCKING AT ENDS OF WALL SYSTEM, ADJACENT TO ALL OPENINGS, AND AT 10'-0" O.C. MAX

1-1/2" x 20 GA. STRAPPING ON EACH SIDE OF WALL STUDS. (STRAPPING TO START, END, & SPLICE AT SOLID BLOCKING)

MIN. 18 GA RUNNER TRACK SOLID BLOCKING @ 10'-0" o.c. MAX. MAKE RUNNER TRACK 8" LONGER THAN STUD INSIDE SPACING. CLIP FLANGES OF TRACK 4" FROM EACH END. BEND TRACK AT CLIPPED FLANGES.

ATTACH BLOCKING TO WALL STUDS w/(2)#10-16 SCREWS IN EACH FLANGE AS SHOWN.

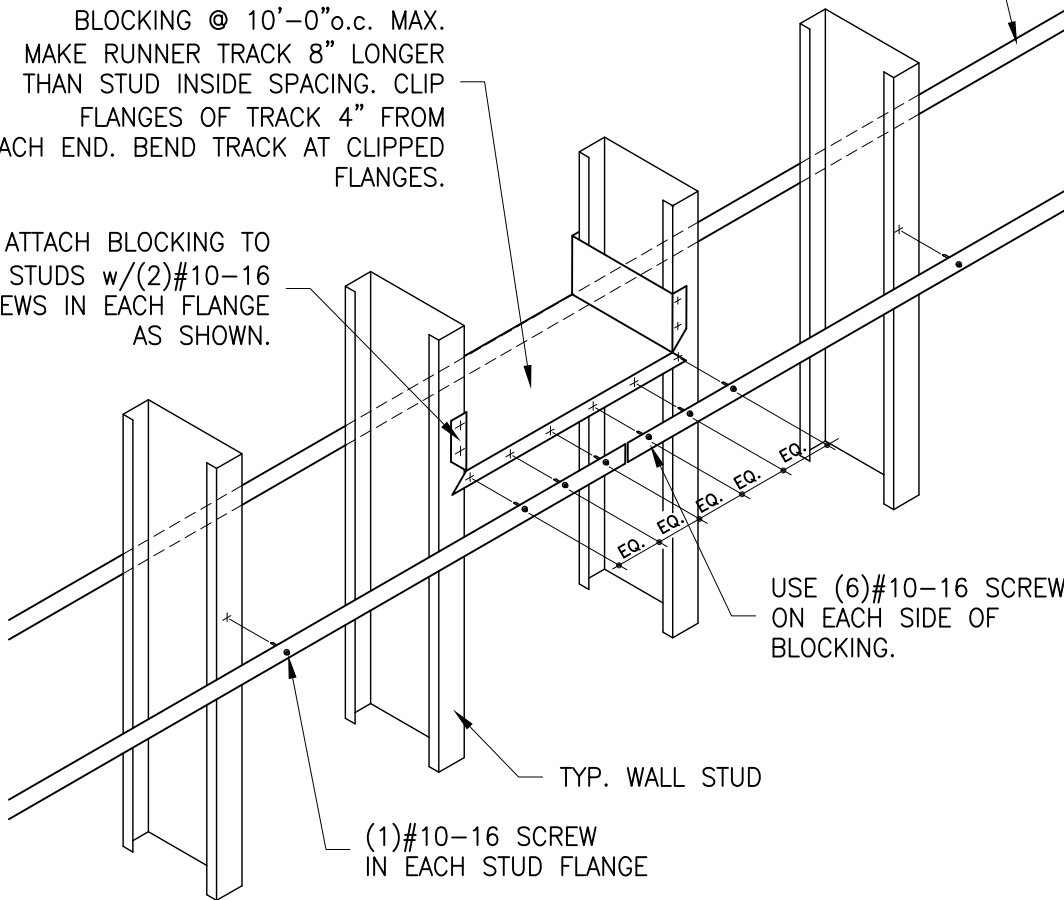

ClarkWestern
Building Systems

Design Services

20 Mansell Court East, Ste 350B | 6510 General Drive | 383 U.S. Route One, Ste 2E
Roswell, GA 30076 | Riverside, Ca. 92509 | Scarborough, ME 04074
toll free 877.832.3206 fax 877.832.3208

STRAPPING LATERAL BRACING

1-1/2" x 20GA. STRAP WITH
RUNNER TRACK BLOCKING