

VERTICAL SECTIONS

DETAIL VIEWS NOT TO SCALE

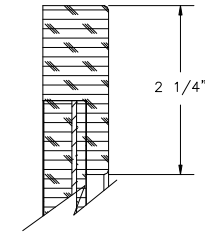
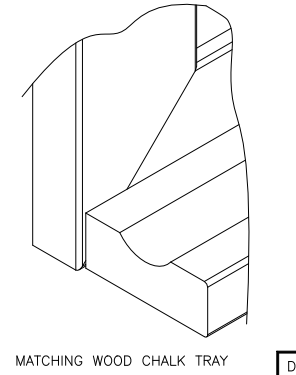
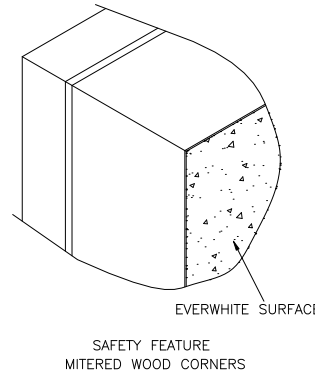

QTY	PART NUMBER / DESCRIPTION	ADDITIONAL COMMENTS

ACCESSORIES SCHEDULE

EVERWHITE COMBINATION BOARDS

- STANDARD SIZES UP TO 4' X 12' WITH VIRTUALLY UNLIMITED CUSTOM SIZES AVAILABLE
- AVAILABLE WITH SELF-HEALING CORK OR VINYL IN MULTIPLE CONFIGURATIONS
- AVAILABLE WITH CUSTOM GRAPHICS IN MULTIPLE CONFIGURATIONS

100% SOLID WOOD FRAME IN OAK OR MAPLE

- STANDARD FINISH OPTIONS:
 - OAK
 - MAPLE
 - STAINED CHERRY
 - STAINED MAHOGANY
- CUSTOM STAIN OPTIONS AVAILABLE UPON REQUEST

EVERWHITE MARKERBOARD
FACE/CORE/BACKING

MAGNETIC

- 01 EWS / 24GS / 1/2" FB / MB

NON-MAGNETIC

- 02 EWS / 1/8" HB / 3/8" FB / MB

- EWS - EVERWHITE SURFACE
- MB - MOISTURE BARRIER SHEET
- HB - HARD BOARD
- FB - FIBER BOARD
- 24GS - 24 GA. GALVANIZED STEEL

CORK & VINYL TACKBOARDS
FACE/CORE/BACKING

- 01 1/4" VFC / 3/8" FB / MB
- 02 1/4" SHC / 3/8" FB / MB

- VFC - VINYL-COATED FABRIC OVER CORK
- SHC - SELF-HEALING CORK
- FB - FIBER BOARD
- MB - MOISTURE BARRIER SHEET



W158 N9332 NOR-X-WAY AVENUE
MENOMONEE FALLS, WI 53051
PH (800) 824-1482
FX (262) 250-7179

CUSTOMER SERVICE AND
SUPPORT (800) 824-1482
WWW.EVERWHITEBOARDS.COM
MADE IN THE USA