

A TYPICAL CEILING HUNG ELEVATION

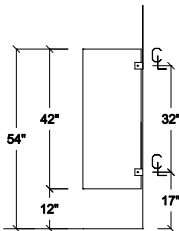
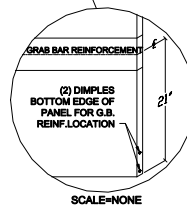
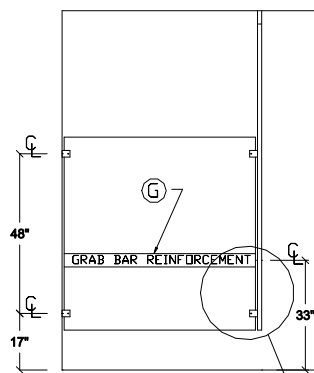

MATERIAL TYPE:

- POWDER COATED METAL

COLOR:

HARDWARE:

- CHROME PLATED ZAMAC DOOR HARDWARE
- #304 STAINLESS STEEL #4 SATIN FINISH DOOR HARDWARE
- CONTINUOUS (54") #304 STAINLESS STEEL #4 SATIN FINISH PIANO HINGES
- CHROME PLATED ZAMAC STIRRUP BRACKETS
- #304 STAINLESS STEEL #4 SATIN FINISH STIRRUP BRACKETS
- CONTINUOUS ANODIZED ALUMINUM BRACKETS
- CONTINUOUS STAINLESS STEEL BRACKETS

DOOR LATCH:

- CONCEALED LATCHES, ADA LEVER/PADDLE HANDLE AT HANDICAPPED DOORS.
- NO SIGHT DOOR STRIP

COMMENTS:

STANDARD HINGE AND STIRRUP BRACKETS SHOWN



2171 LIBERTY HILL ROAD, EASTANOLLEE, GA 30538

NO.	DATE:	REVISION	JOB:	SCALE: 3/8" = 1'
			LOC:	BY:
			ARCH:	DATE:
			CONTR:	SHEET:
		P.O. #	DIST:	JOB #

FOR A DETAILED COPY OF OUR INSTALLATION INSTRUCTIONS PLEASE VISIT OUR WEBSITE AT WWW.GLOBALPARTITIONS.COM