

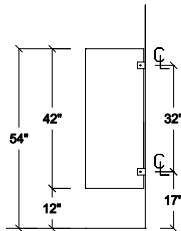

A TYPICAL FLOOR TO CEILING ELEVATION

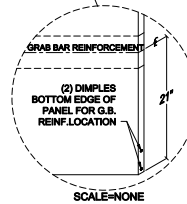
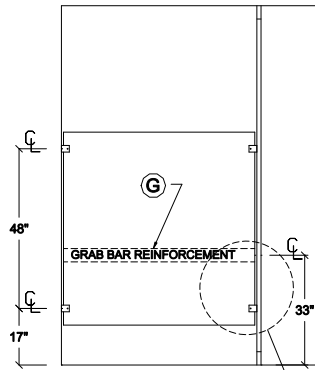

FOR A DETAILED COPY OF OUR INSTALLATION INSTRUCTIONS PLEASE VISIT OUR WEBSITE AT WWW.GLOBALPARTITIONS.COM

MATERIAL TYPE:				
<input type="checkbox"/>	POWDER COATED METAL			
COLOR:				
HARDWARE:				
<input type="checkbox"/>	CHROME PLATED ZAMAC DOOR HARDWARE			
<input type="checkbox"/>	#304 STAINLESS STEEL #4 SATIN FINISH DOOR HARDWARE			
<input type="checkbox"/>	CONTINUOUS (54") #304 STAINLESS STEEL #4 SATIN FINISH PIANO HINGES			
<input type="checkbox"/>	CHROME PLATED ZAMAC STIRRUP BRACKETS			
<input type="checkbox"/>	#304 STAINLESS STEEL #4 SATIN FINISH STIRRUP BRACKETS			
<input type="checkbox"/>	CONTINUOUS ANODIZED ALUMINUM BRACKETS			
<input type="checkbox"/>	CONTINUOUS STAINLESS STEEL BRACKETS			
DOOR LATCH:				
<input type="checkbox"/>	CONCEALED LATCHES, ADA LEVER/PADDLE HANDLE AT HANDICAPPED DOORS.			
<input type="checkbox"/>	NO SIGHT DOOR STRIP			
COMMENTS:				
STANDARD HINGE AND STIRRUP BRACKETS SHOWN				
 2171 LIBERTY HILL ROAD, EASTANOLLEE, GA 30538				
NO.	DATE:	REVISION	JOB:	SCALE: 3/8" = 1'
			LOC:	BY:
			ARCH:	DATE:
			CONTR:	SHEET:
		P.O. #	DIST:	JOB #