

**NOTE:**

JOINTS SHOULD BE CLEANED AND SEALANT SHOULD BE APPLIED TO ALL JOINTS GENEROUSLY AND TOOLED, THUS INSURING A LEAK-PROOF SEAL. IMPROPERLY APPLIED SEALANT CAN RESULT IN WATER LEAKAGE.

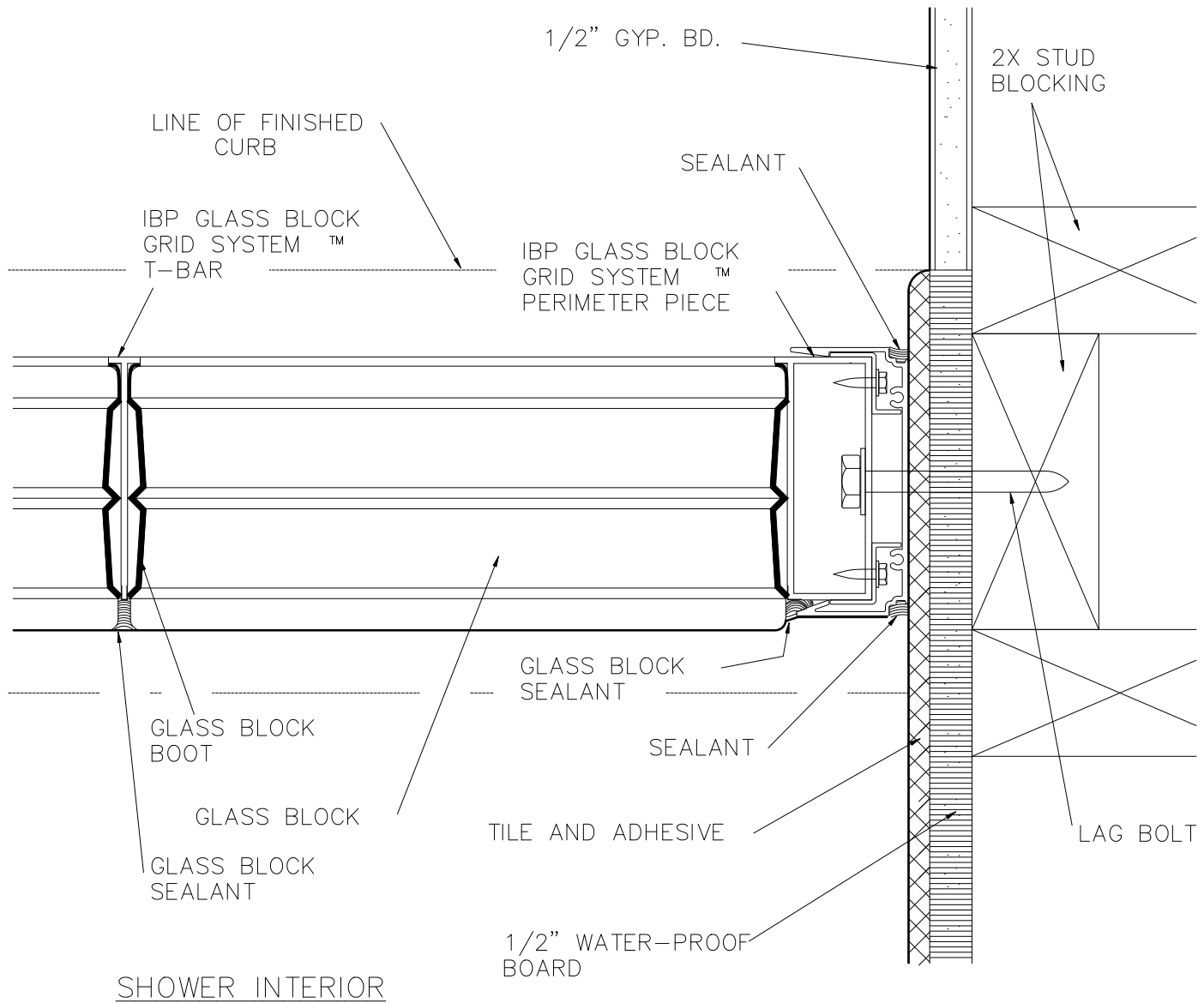

**SHOWER AT WALL DETAIL**

SCALE: 1/2" = 1"

Because IBP has no control over installation, workmanship, accessory materials, or conditions of application, no representation or warranty, expressed or implied, either as to MERCHANTABILITY OR FITNESS FOR A PARTICULAR PURPOSE is made as to the performance or results of an installation of this product.

**IBP glass block grid system™**  
 WINDOWS SKYLIGHTS FLOORS SHOWERS WALLS  
 Innovative Building Products, Inc. • 2917 West 7th St. • Fort Worth, TX 76107  
 Phone: (817) 332-9124 • Fax: (817) 332-9128  
 www.ibpglassblock.com

IBP Glass Block Grid System™  
 is a trademark of Innovative Building Products, Inc. • Fort Worth, TX, USA  
 U.S. Patent Numbers:  
 4294649 • 4999964 • 5003744 • 5042210 • 5218806  
 Australia: 634975 • 638988 Canada: 1328970 • 2015714  
 Brazil: P18904269-7 Greece: 3010097 • 3017183 Ireland: 62,450 • 67,796  
 European: 0396075 • 0356374 Mexico: 165468 • 172717  
 New Zealand: 230417 • 233568 Other patents pending worldwide

SH-2  
 AUG 01