

REAR VIEW

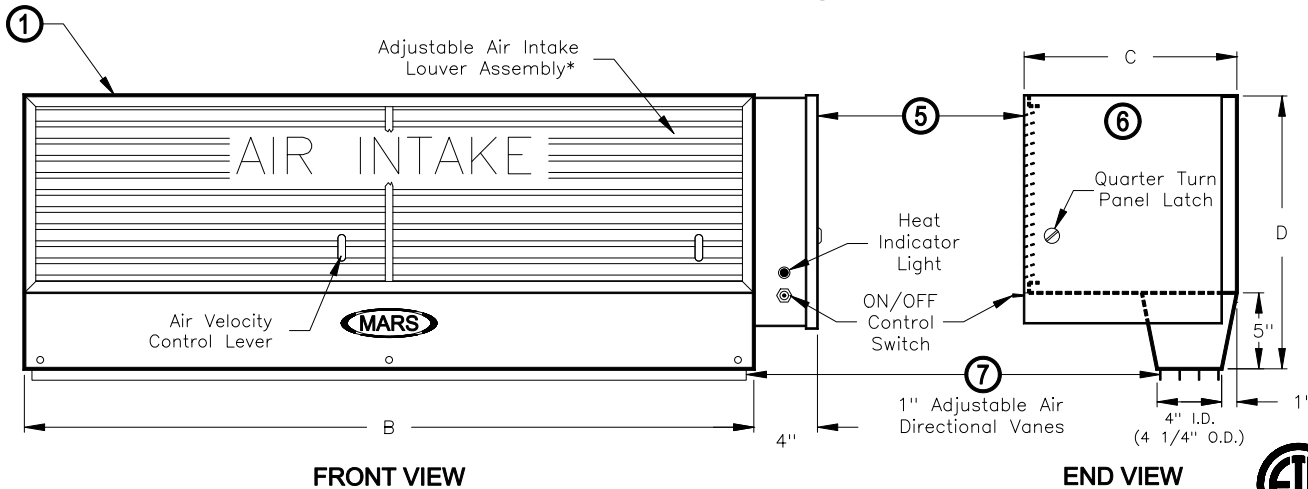

FRONT VIEW

END VIEW

NOTES:

- ① This product is designed to comply with the National Electric Code (NEC) and is ETL certified.
- ② 7/16" mounting holes, (4) provided, (2) on each end.
- ③ All units have a self contained one piece cabinet, fire retardant and corrosion proof paint lock metal, double protected with baked on gray color rust preventative electrostatic polyurethane powdercoating.
- ④ Cabinet has sufficient strength for suspension from both ends without intermediate support.
- ⑤ Allow a minimum of 17" clearance for access to control panel door for installation and maintenance.
- ⑥ Control panel is prewired and premounted or right hand hand side of cabinet, specify for alternate location.
- ⑦ Unit is to be installed such that air flow is unobstructed. Air discharge nozzle containing adjustable air directional vanes with 40° sweep front to back.
- ⑧ Wall mounted 24 volt thermostat with remote "heat/off/fan" switch shipped loose and field installed. Terminal block provided inside panel.
- ⑨ Branch circuit protected as per NEC by others.
- ⑩ Optional microswitch is field installed. Terminal block provided inside panel. Switch to be mounted such that the air curtain turns on as door begins to open. A time delay is highly recommended with the optional microswitch.

-2 & -3 designates the number of motors.

*NOTE: Louver assembly size and number varies with unit length.



MODEL NUMBER	MOUNTING CENTERS A	LENGTH B	DEPTH C	HEIGHT D
E36	35 1/8"	36"	11 1/4"	15 3/8"
E38	37 1/8"	38"	11 1/4"	15 3/8"
E42	41 1/8"	42"	11 1/4"	15 3/8"
E48	47 1/8"	48"	11 1/4"	15 3/8"
E60	59 1/8"	60"	11 1/4"	15 3/8"
E64-2	63 1/8"	64"	11 1/4"	15 3/8"
E72-2	71 1/8"	72"	11 1/4"	15 3/8"
E78-2	77 1/8"	78"	11 1/4"	15 3/8"
E84-2	83 1/8"	84"	11 1/4"	15 3/8"
E96-2	95 1/8"	96"	11 1/4"	15 3/8"
E96-3	95 1/8"	96"	11 1/4"	15 3/8"
E108-3	107 1/8"	108"	11 1/4"	15 3/8"
E120-3	119 1/8"	120"	11 1/4"	15 3/8"
E144-3	143 1/8"	144"	11 1/4"	15 3/8"

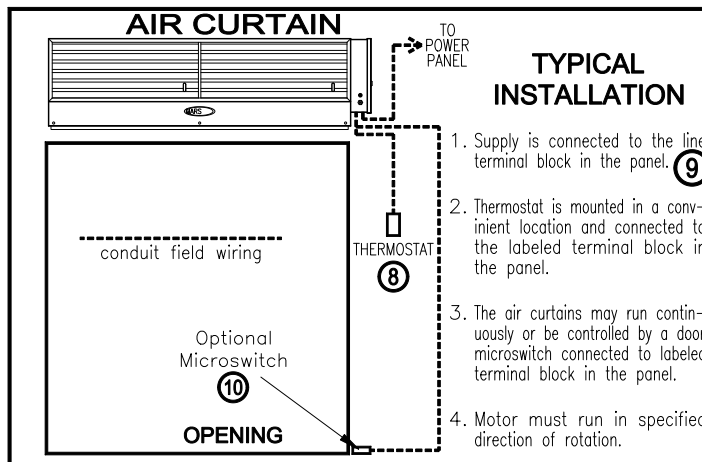

PROJECT	MODEL NO.
LOCATION	DRAWING NO.
ARCHITECT	DATE
ENGINEER	SHEET OF
	DRAWN BY
	CHECKED BY
	PROJECT NO.

BRAND AIR CURTAIN

14716 S. BROADWAY • GARDENA, CA 90248
 Phone: 310-532-1555 • 800-421-1266 • Fax: 310-324-3030
 WEB SITE: www.marsair.com • E-MAIL: marsinfo@marsair.com

1/2 HP STANDARD ELECTRIC HEATED MODELS