

**MASCO CASTinTACT® | 36" BLENDED TRANSITION**  
**THIN SET INSTALLATION**

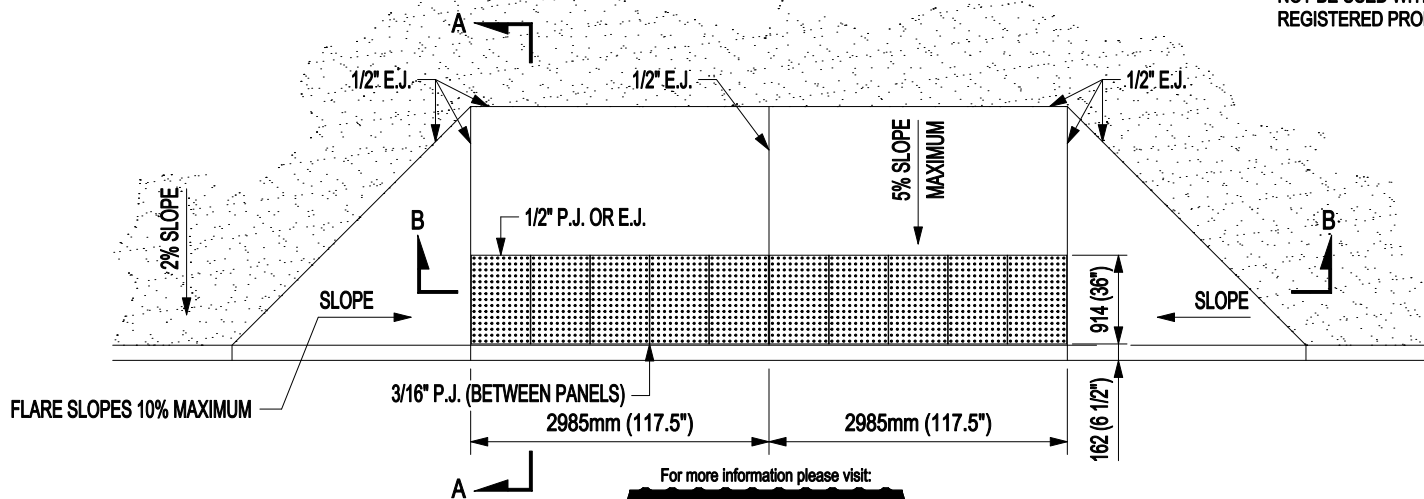
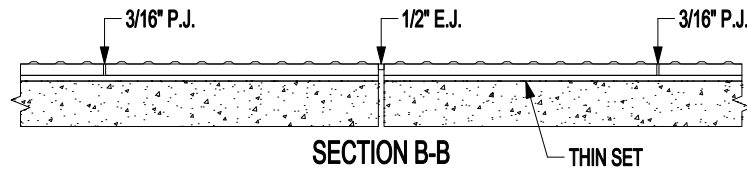
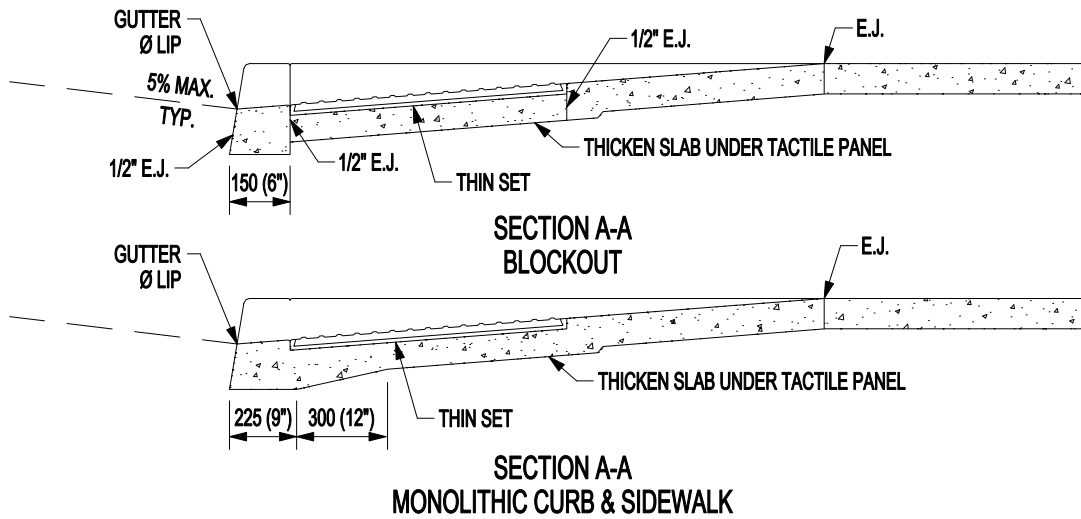

**GENERAL NOTES**

1. SIDEWALK RAMP DETAILS ARE BASED ON UNITED STATES ACCESS BOARD STANDARDS.
2. PLACE TRUNCATED DOME DETECTABLE WARNING PANELS AT THE BASE OF CURB RAMP. INSTALL ACROSS FULL WIDTH OF RAMP A MINIMUM 610mm (24") IN DEPTH AND SET BACK 200mm (8") FROM GRADE BREAK.
3. SIDEWALK CURB RAMP SLOPES SHOWN ARE RELATIVE TO THE TRUE LEVEL HORIZON (ZERO BUBBLE).
4. SIDE FLARES THAT ARE NOT PART OF THE PATH OF TRAVEL MAY BE ANY SLOPE.
5. JOINTS ARE REQUIRED AT ALL SIDEWALK RAMP SLOPE BREAKS. EXPANSION JOINTS ARE RECOMMENDED BETWEEN CONCRETE AND NEW WHERE APPLICABLE. (REFER TO ACI 360R)
6. SIDEWALK FLARE IS NOT NECESSARY WHERE THE RAMP IS PROTECTED FROM PEDESTRIAN CROSS TRAVEL.
7. THICKEN CONCRETE UNDER DETECTABLE WARNING PANEL.
8. IN EXTREME CLIMATES LEAVE 3/16" GAP BETWEEN SQUARE CUT PANEL JOINTS AND SEAL WITH A COMPATIBLE ELASTOMERIC SEALANT.
9. ONLY USE DETAILS ALLOWED BY JURISDICTION.

E.J. = EXPANSION JOINT      P.J. = PANEL JOINT

THE SELECTION AND USE OF THIS DRAWING WHILE DESIGNATED IN ACCORDANCE WITH GENERALLY ACCEPTABLE ENGINEERING PRINCIPLES AND PRACTICES, IS THE SOLE RESPONSIBILITY OF THE USER AND SHOULD NOT BE USED WITHOUT CONSULTING A REGISTERED PROFESSIONAL ENGINEER.