

# MODEL TP-20

SYMMETRICAL 2-POST LIFT  
CAPACITY: 20,000 LBS



THIS LIFT HAS BEEN TESTED AND CERTIFIED BY A NATIONALLY RECOGNIZED TESTING LABORATORY (NRTL) TO MEET THE REQUIREMENTS OF U.L. STANDARD 201 FOR GARAGE EQUIPMENT AND ANSI/ALI ALCTV-2006 FOR AUTOMOTIVE LIFT CONSTRUCTION.

CONTACT MOHAWK RESOURCES LTD. FOR ADDITIONAL SPECIFICATIONS AND/OR SPECIFICATION DRAWINGS.

SCALE: FULL  
DRAWN BY: R.V.  
REV DATE: 5/2006

NOTE:  
LIFT SPECIFICATIONS SUBJECT TO CHANGE WITHOUT NOTICE. SEE README.TXT FOR ADDITIONAL NOTES PERTAINING TO ALL CAD DRAWINGS.

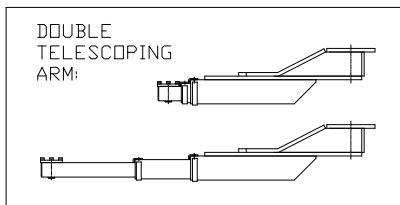
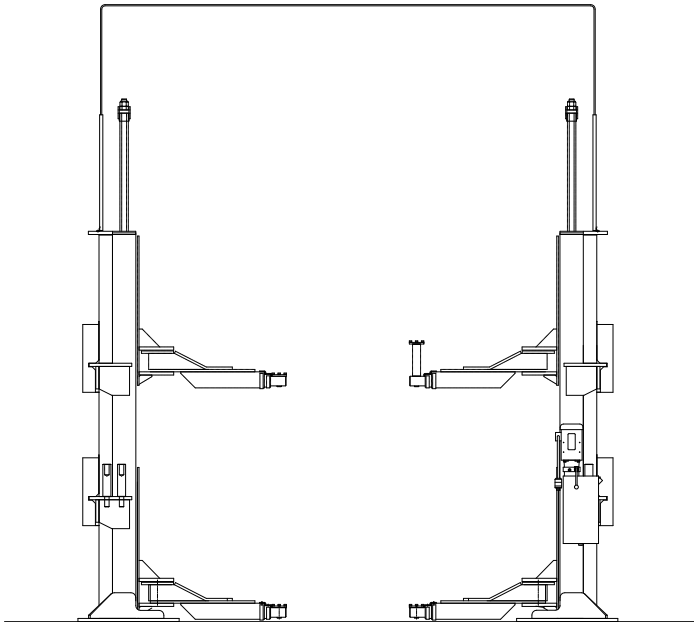

## MOHAWK RESOURCES LTD.

P.O. BOX 110  
65 VROOMAN AVENUE  
AMSTERDAM, NY 12010

PHN: (800) 833-2006  
IN NY: (518) 842-1431  
FAX: (518) 842-1289