

Plan Elevation

WALL FASTENERS ARE AVAILABLE AS (1 1/2" STANDARD) OR (2 1/2" OPTIONAL).
 **ACTUAL PART DESIGN MAY DIFFER FROM THE DRAWING ABOVE.

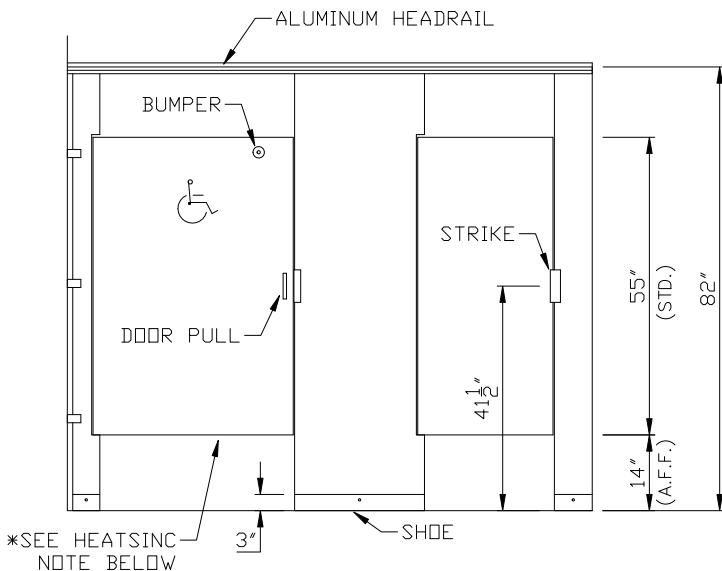

Front Elevation

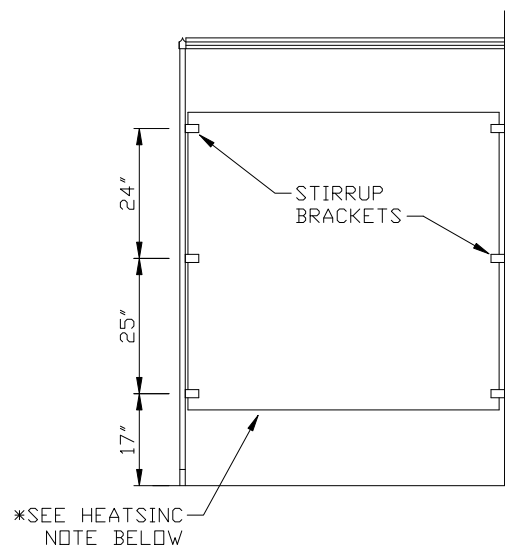

Side Elevation

C:\DOCUME~1\mmoraski\LOCALS~1\Temp\A#C73E32FA4.dib

STANDARD ELEVATIONS

(Drawings are not to scale)

*Floor Mounted Overhead Braced

*Integral Hinge

*Stirrup Brackets

Note: "Job-Specific Specifications" for all orders are located on the top of the shop drawing layouts.

* HEATSINC NOTE: Heatsinc is to be placed on the bottom of the panels & doors. (If specified)

Details

