

TS6WTC5 or TS1WTC5 – Welded Truss Clip

TS6WTC5		
Total Uplift Capacity lbs. (kN)		
Chord Gauge	Clip on one side	Clip on each side
28TSC – 22g	730 (3.25)	3280 (14.59)
33TSC – 20g	730 (3.25)	4080 (18.15)
43TSC – 18g	730 (3.25)	6080 (27.05)
54TSC – 16g	730 (3.25)	6980 (31.05)

TS1WTC5		
Total Uplift Capacity lbs. (kN)		
Chord Gauge	Clip on one side	Clip on each side
28TSC – 22g	730 (3.25)	3280 (14.59)
33TSC – 20g	730 (3.25)	4080 (18.15)
43TSC – 18g	730 (3.25)	6080 (27.05)
54TSC – 16g	730 (3.25)	8152 (36.26)

– The uplift capacities shown above have been increased by 1.33 and may be used only for uplift resulting from wind or seismic loads. For uplift due to other loads, use 75% of tabulated values.

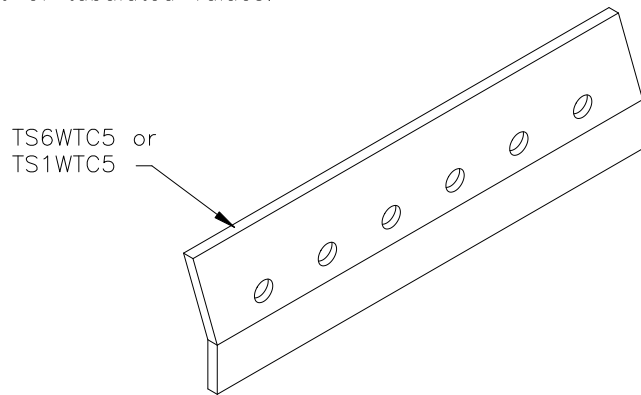

TS6WTC5 is 16g t = 0.0538 in. (1.37mm)
 TS1WTC5 is 10g t = 0.128 in. (3.25mm)

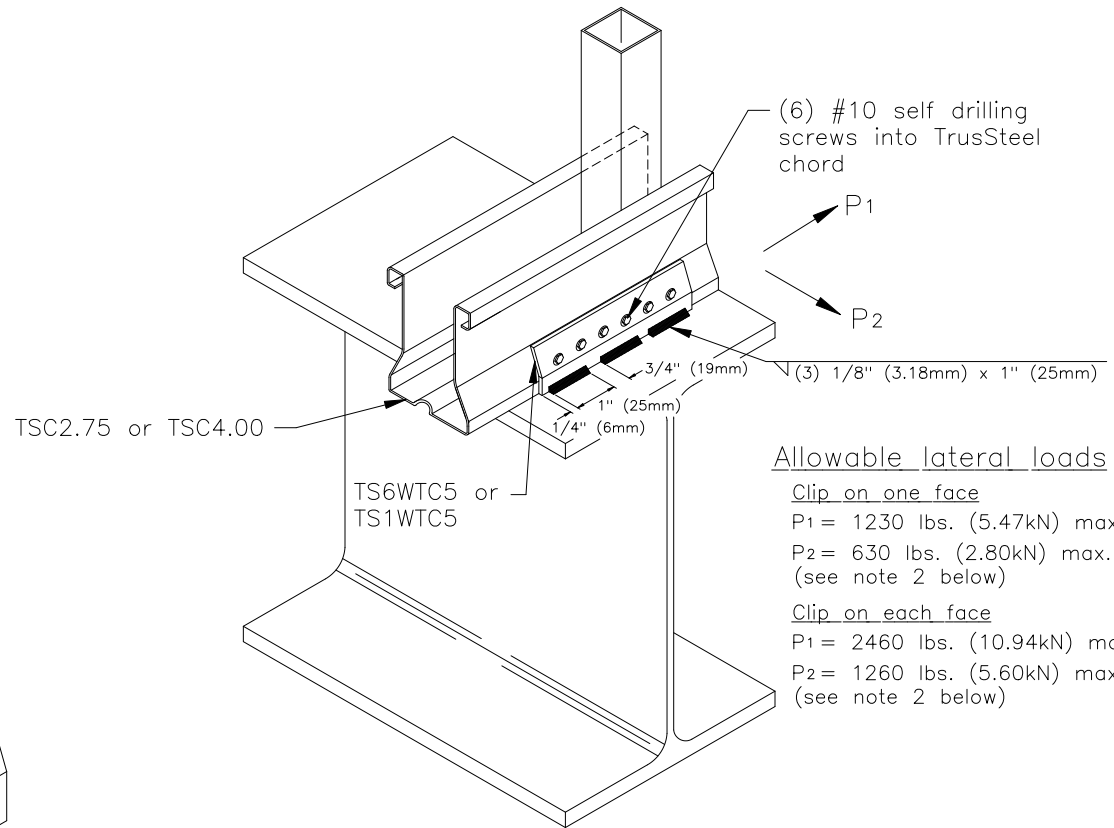

Allowable lateral loads

Clip on one face

P1 = 1230 lbs. (5.47kN) max.
 P2 = 630 lbs. (2.80kN) max.
 (see note 2 below)

Clip on each face

P1 = 2460 lbs. (10.94kN) max.
 P2 = 1260 lbs. (5.60kN) max.
 (see note 2 below)

General Notes:

1. Attachment of second clip on opposite face of chord is identical to what is detailed.
2. Lateral allowable loads (P1 and P2) shown are maximum values. If these loads are in combination with an uplift load, contact an engineer from Alpine Engineered Products, Inc.
3. Weld values based on the use of an E70XX electrode.
4. Refer to TrusSteel Technical Bulletin 98.10.05 titled "Repair of Galvanized Surfaces" to restore corrosion resistant properties of the connection after welding.

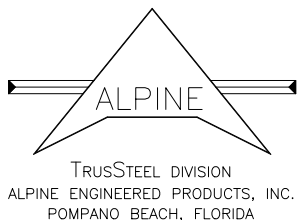

****WARNING**** TRUSSES REQUIRE EXTREME CARE IN FABRICATING, HANDLING, SHIPPING INSTALLING AND BRACING. UNLESS OTHERWISE INDICATED, TOP CHORD SHALL HAVE PROPERLY ATTACHED STRUCTURAL PANELS AND BOTTOM CHORD SHALL HAVE A PROPERLY ATTACHED RIGID CEILING.

****IMPORTANT**** FURNISH A COPY OF THIS DESIGN TO THE INSTALLATION CONTRACTOR. BRACING DEPICTED ON THIS DESIGN IS ONLY FOR LATERAL SUPPORT OF TRUSS MEMBERS TO REDUCE BUCKLING LENGTHS. ALL DESIGN, ATTACHMENT AND INSTALLATION OF TEMPORARY AND PERMANENT BRACING, TO RESIST LATERAL FORCES AND HOLD TRUSSES PLUMB, SHALL BE THE RESPONSIBILITY OF OTHERS. ALPINE ENGINEERED PRODUCTS, INC. SHALL NOT BE RESPONSIBLE FOR ANY DEVIATION FROM THIS DESIGN OR HANDLING, SHIPPING, INSTALLING, AND BRACING OF TRUSSES. AN ENGINEER'S SEAL ON THIS DRAWING APPLIES ONLY TO DESIGN OF THE TRUSS DEPICTED HERE AND SHALL NOT BE RELIED UPON IN OTHER WAY.

TrusSTEEL DETAIL	
DATE	12/21/01
DRWG	TS027A
–ENG	