

# TSUC5 Uplift Attachment to Light Gauge Steel

| Total Uplift Capacity lbs. (kN)  |                  |                   |
|----------------------------------|------------------|-------------------|
| Wall top plate/min. thickness    | Clip on one face | Clip on each face |
| 22g grade 33/0.0269 in. (0.68mm) | 380 (1.69)       | 910 (4.05)        |
| 22g grade 50/0.0269 in. (0.68mm) | 540 (2.40)       | 1320 (5.87)       |
| 20g grade 33/0.0328 in. (0.83mm) | 470 (2.09)       | 1120 (4.98)       |
| 20g grade 50/0.0328 in. (0.83mm) | 540 (2.40)       | 1610 (7.16)       |
| 18g grade 33/0.0428 in. (1.09mm) | 540 (2.40)       | 1450 (6.45)       |
| 18g grade 50/0.0428 in. (1.09mm) | 540 (2.40)       | 2100 (9.34)       |
| 16g grade 33/0.0538 in. (1.37mm) | 540 (2.40)       | 1820 (8.10)       |
| 16g grade 50/0.0538 in. (1.37mm) | 540 (2.40)       | 2630 (11.70)      |
| 14g grade 33/0.0677 in. (1.72mm) | 540 (2.40)       | 2300 (10.23)      |
| 14g grade 50/0.0677 in. (1.72mm) | 540 (2.40)       | 2730 (12.14)      |
| 12g grade 33/0.0966 in. (2.45mm) | 540 (2.40)       | 2730 (12.14)      |
| 12g grade 50/0.0966 in. (2.45mm) | 540 (2.40)       | 2730 (12.14)      |

– The uplift capacities shown above have been increased by 1.33 and may be used only for uplift resulting from wind or seismic loads. For uplift due to other loads, use 75% of tabulated values.

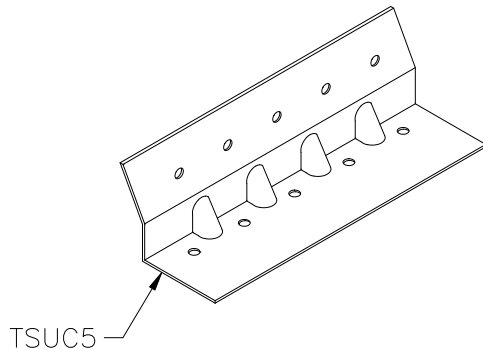
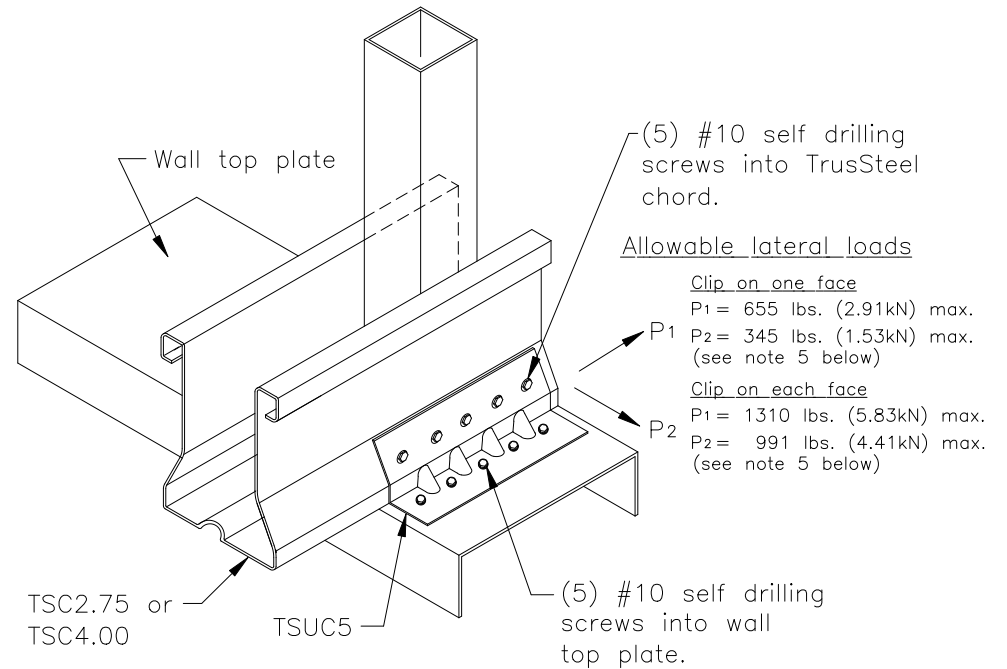

### General Notes:

1. Wall top plate is made of ASTM A653–96 SS grade 33 or grade 50 steel. Top plate width is 5–1/2" (140mm).
2. Attachment of second clip on opposite face of chord is identical to what is detailed.
3. Connection of top plate to wall stud must be capable of transferring truss uplift load from wall top plate to wall stud.
4. The wall top plate is to be designed by the job engineer. The wall top plate must be designed to support the loads applied to it (downward, upward and lateral).
5. Lateral allowable loads (P1 and P2) shown are maximum values. If these loads are in combination with an uplift load, contact an engineer from Alpine Engineered Products, Inc.

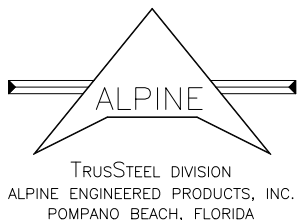

**\*\*WARNING\*\*** TRUSSES REQUIRE EXTREME CARE IN FABRICATING, HANDLING, SHIPPING INSTALLING AND BRACING. UNLESS OTHERWISE INDICATED, TOP CHORD SHALL HAVE PROPERLY ATTACHED STRUCTURAL PANELS AND BOTTOM CHORD SHALL HAVE A PROPERLY ATTACHED RIGID CEILING.

**\*\*IMPORTANT\*\*** FURNISH A COPY OF THIS DESIGN TO THE INSTALLATION CONTRACTOR. BRACING DEPICTED ON THIS DESIGN IS ONLY FOR LATERAL SUPPORT OF TRUSS MEMBERS TO REDUCE BUCKLING LENGTHS. ALL DESIGN, ATTACHMENT AND INSTALLATION OF TEMPORARY AND PERMANENT BRACING, TO RESIST LATERAL FORCES AND HOLD TRUSSES PLUMB, SHALL BE THE RESPONSIBILITY OF OTHERS. ALPINE ENGINEERED PRODUCTS, INC. SHALL NOT BE RESPONSIBLE FOR ANY DEVIATION FROM THIS DESIGN OR HANDLING, SHIPPING, INSTALLING, AND BRACING OF TRUSSES. AN ENGINEER'S SEAL ON THIS DRAWING APPLIES ONLY TO DESIGN OF THE TRUSS DEPICTED HERE AND SHALL NOT BE RELIED UPON IN OTHER WAY.

TRUSSTEEL DETAIL  
 DATE 12/21/01  
 DRWG TS029  
 –ENG