

TSK4L/R HANGER APPLICATION WITH MINIMUM SCREWS

(4-#10 SCREWS IN HANGER-TO-SUPPORTED TRUSS CONNECTION)

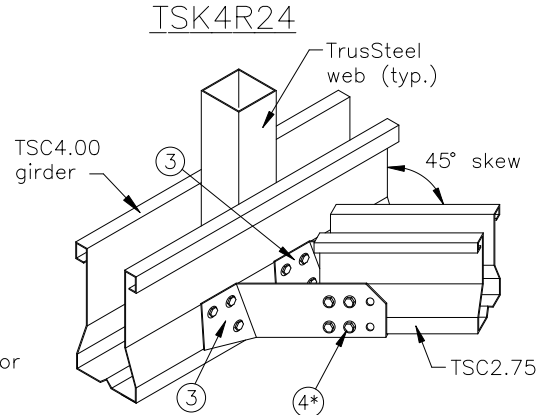
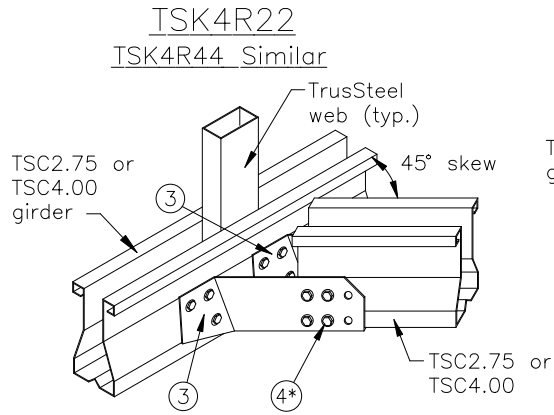
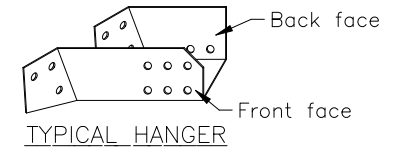

Tube for TSC2.75 chord:
33W.75x1.5 .75x1.5-33-45ksi tube attached to chord with 14AMDB1.25 screws at 6" (152mm) O.C.

Tube for TSC4.00 chord:
33W1.5x1.5 1.5x1.5-33-45ksi tube attached to chord with 14AMDB2.125 screws at 6" (152mm) O.C.
Tube length = (panel length) - 18" (457mm)

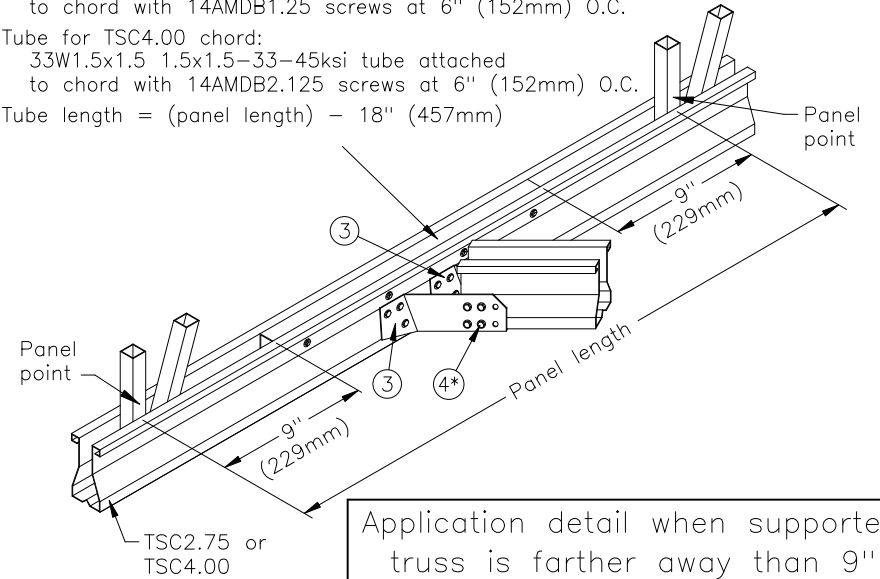

Application detail when supported truss is at or within 9" (229mm) of a panel point

*4 screws through front face (shown)
No screws through back face

Application detail when supported truss is farther away than 9" (229mm) from a panel point

TSK4 Allowable Load Table			
Load Orientation	Allowable load lbs. (kN)		
	TSK4L22/ TSK4R22	TSK4L24/ TSK4R24	TSK4L44/ TSK4R44
Downward	270 (1.20)	270 (1.20)	240 (1.07)
Uplift (gravity)	150 (0.67)	150 (0.67)	100 (0.44)
Uplift (wind)	200 (0.89)	200 (0.89)	130 (0.58)

- The wind uplift capacities shown above have been increased by 1.33 and may be used only for uplift resulting from wind or seismic loads.
- Allowable loads given above may be used with TrusSteel chords of any thickness.

General Notes:

1. Circled numbers represent the quantity of #10 self-drilling sheet metal screws applied through the pre-drilled holes in hanger into the TrusSteel chord.
2. Screws connecting the hanger to the girder chord shall be applied first.
3. Do not overdrive screws. Overdriven screws may strip out of TrusSteel chord.
4. Refer to TrusSteel detail drawings TS023, TS024 or TS024A for ply-to-ply connections for multiple member girders.
5. Hangers skewed 45° to the right are shown above. TSK4L22, TSK4L24 and TSK4L44 are similar, but skewed to the left.

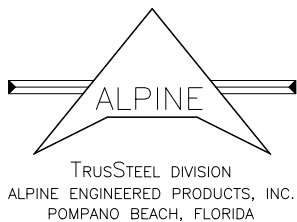

****WARNING**** TRUSSES REQUIRE EXTREME CARE IN FABRICATING, HANDLING, SHIPPING INSTALLING AND BRACING. UNLESS OTHERWISE INDICATED, TOP CHORD SHALL HAVE PROPERLY ATTACHED STRUCTURAL PANELS AND BOTTOM CHORD SHALL HAVE A PROPERLY ATTACHED RIGID CEILING.

****IMPORTANT**** FURNISH A COPY OF THIS DESIGN TO THE INSTALLATION CONTRACTOR. BRACING DEPICTED ON THIS DESIGN IS ONLY FOR LATERAL SUPPORT OF TRUSS MEMBERS TO REDUCE BUCKLING LENGTHS. ALL DESIGN, ATTACHMENT AND INSTALLATION OF TEMPORARY AND PERMANENT BRACING, TO RESIST LATERAL FORCES AND HOLD TRUSSES PLUMB, SHALL BE THE RESPONSIBILITY OF OTHERS. ALPINE ENGINEERED PRODUCTS, INC. SHALL NOT BE RESPONSIBLE FOR ANY DEVIATION FROM THIS DESIGN OR HANDLING, SHIPPING, INSTALLING, AND BRACING OF TRUSSES. AN ENGINEER'S SEAL ON THIS DRAWING APPLIES ONLY TO DESIGN OF THE TRUSS DEPICTED HERE AND SHALL NOT BE RELIED UPON IN OTHER WAY.

TrusSteel DETAIL
DATE 12/21/01
DRWG TS038A
-ENG