

VersiWeld[®] ROOFING SYSTEM

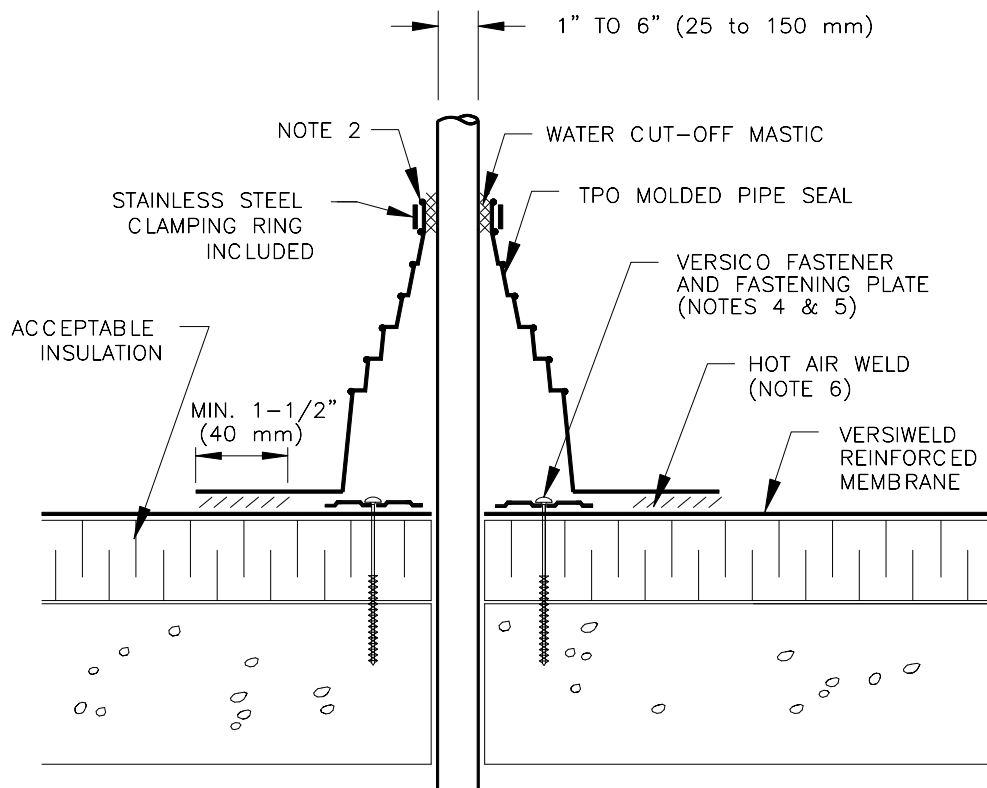

NOTES:

1. REMOVE ALL LEAD AND OTHER FLASHING.
2. TEMPERATURE OF PIPE MUST NOT EXCEED 120° F (49° C).
3. PIPE SEAL MUST HAVE INTACT RIB AT TOP EDGE, REGARDLESS OF PIPE DIAMETER.
4. INSTALL 3 FASTENERS AND PLATES AROUND PIPE EQUALLY SPACED. FASTENERS MAY ALSO BE POSITIONED MAXIMUM 12" (300 mm) FROM PIPE, FASTENED 12" ON CENTER AND FLASHED WITH VERSIWELD REINFORCED MEMBRANE.

FASTENERS/PLATES ARE NOT REQUIRED ON ADHERED SYSTEMS UNLESS PIPE DIAMETER EXCEEDS 18" (500 mm).

5. IF PLATES CANNOT BE INSTALLED AS SHOWN THEY CAN BE POSITIONED OUTSIDE THE PIPE FLASHING FLANGE AS SHOWN ON DETAIL VWC-8.6.
6. PIPE SEAL DECK FLANGE MUST BE HOT AIR WELDED A MINIMUM OF 1-1/2" (40 mm) BEYOND FASTENING PLATES.
7. INSTALL A SECTION OF VERSIWELD REINFORCED MEMBRANE OVER SPLICE INTERSECTIONS PRIOR TO INSTALLING TPO MOLDED PIPE SEAL.

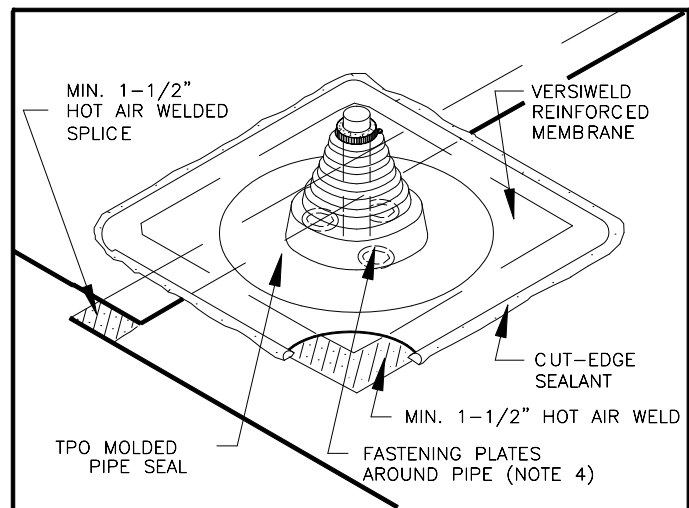

VWC-8.1

TPO MOLDED PIPE SEAL

VERSICO
INCORPORATED



A subsidiary of Carlisle SynTec Incorporated
© 2006 VERSICO INCORPORATED