

SECTION B-B
POST CONNECTION

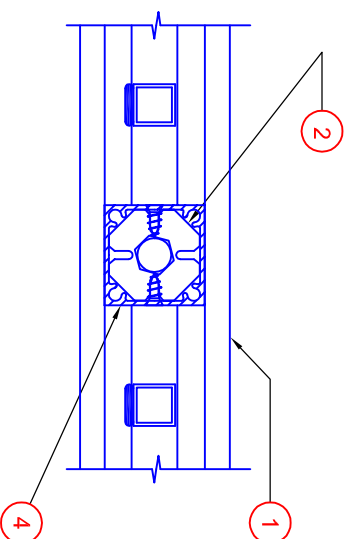

ELEVATION

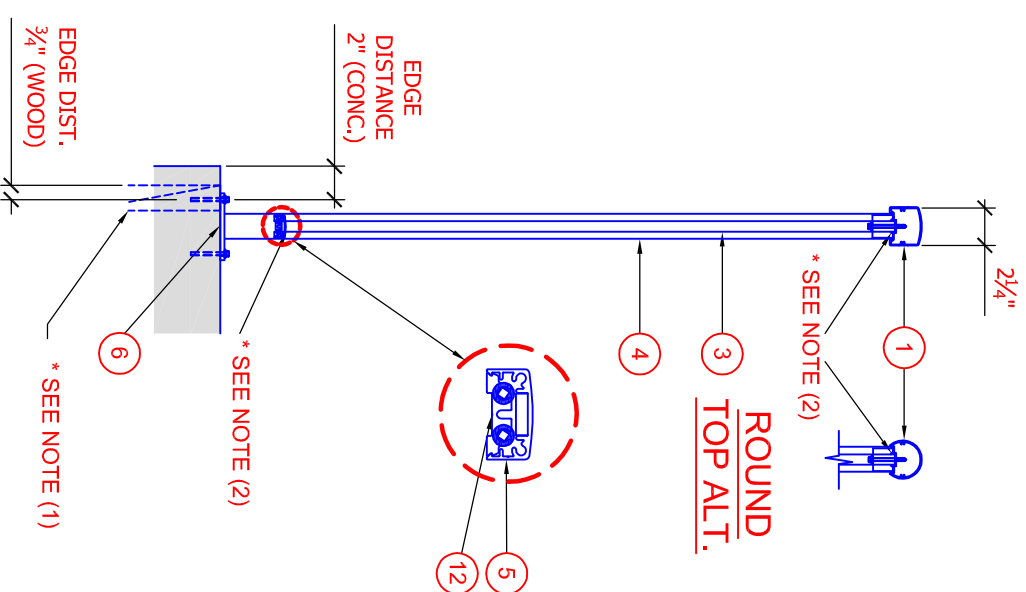

SECTION A-A

- NOTES:
 (1) BUILDING GENERAL CONTRACTOR IS RESPONSIBLE FOR PROVIDING ADEQUATE BACKING IN WALLS AND FLOORS TO AFFIX TO THE BUILDING THE ALUMINUM GUARDRAIL LAYOUT DEFINED IN THESE DRAWINGS
 (2) WELD PICKET TO UNDERSIDE OF TOP OF PART #1 OR #5

ITEM	DESCRIPTION
1	2 1/4" SQUARE □ OR ROUND TOP □ RAIL (CHECK CORRECT BOX)
2	RAIL/POST CONNECTOR C/W #14 X 2" HEX HEAD SCREW TO RAIL & (2) - #8 X 3/4" SCREWS TO POST
3	5/8" X 5/8" ALUMINUM PICKET
4	1 1/2" STANDARD ALUMINUM POST
5	1 3/8" X 3/4" BOTTOM CHANNEL
6	4" X 4" X 1/4" BASE C/W (4) - 5/8" Ø X 3 1/4" LAG SCREW INTO WOOD OR (4) - 3/8" Ø X 3" KWIK BOLTS II ANCHORS INTO CONCRETE AND TO POST W/ (4) #12 X 2" FLAT HEAD SCREWS
7	PICKET LEG C/W 1/4" Ø X 2 1/2" SCREW INTO WOOD OR #14 X 2" "TAPCON" ANCHOR INTO CONCRETE (NOT SHOWN)
8	(NOT SHOWN)
9	TOP RAIL END CLIP C/W (2) 1/4" Ø X 2 1/2" SCREWS INTO WOOD OR (2) #14 X 1" SCREWS INTO ALUMINUM POST & (2) #8 X 1 1/4" FLAT HEAD SCREWS TO TOP RAIL
10	BOTTOM RAIL END CLIP C/W (2) 1/4" Ø X 2 1/2" SCREWS INTO WOOD OR (2) #14 X 1" SCREW INTO ALUMINUM POST AND (2) #8 X 1 1/4" FLAT HEAD SCREWS TO BOTTOM RAIL
11	(NOT SHOWN)
12	CHANNEL BLOCK C/W (2) #10 X 2" SCREWS TO POST

PROJECT:

CLIENT:

SITE LOCATION:

DRAWN	PROJECT
DESIGNED	CHECKED
SCALE	NTS
CREATED	JAN 07

No	DATE	ISSUE - REVISION
----	------	------------------

TOP MOUNT 1.5" POST GUARD W/ PICKETS
 DWG No. **TP1.5**