

Approval

Confirmation

Making

**PRODUCT DRAWING**

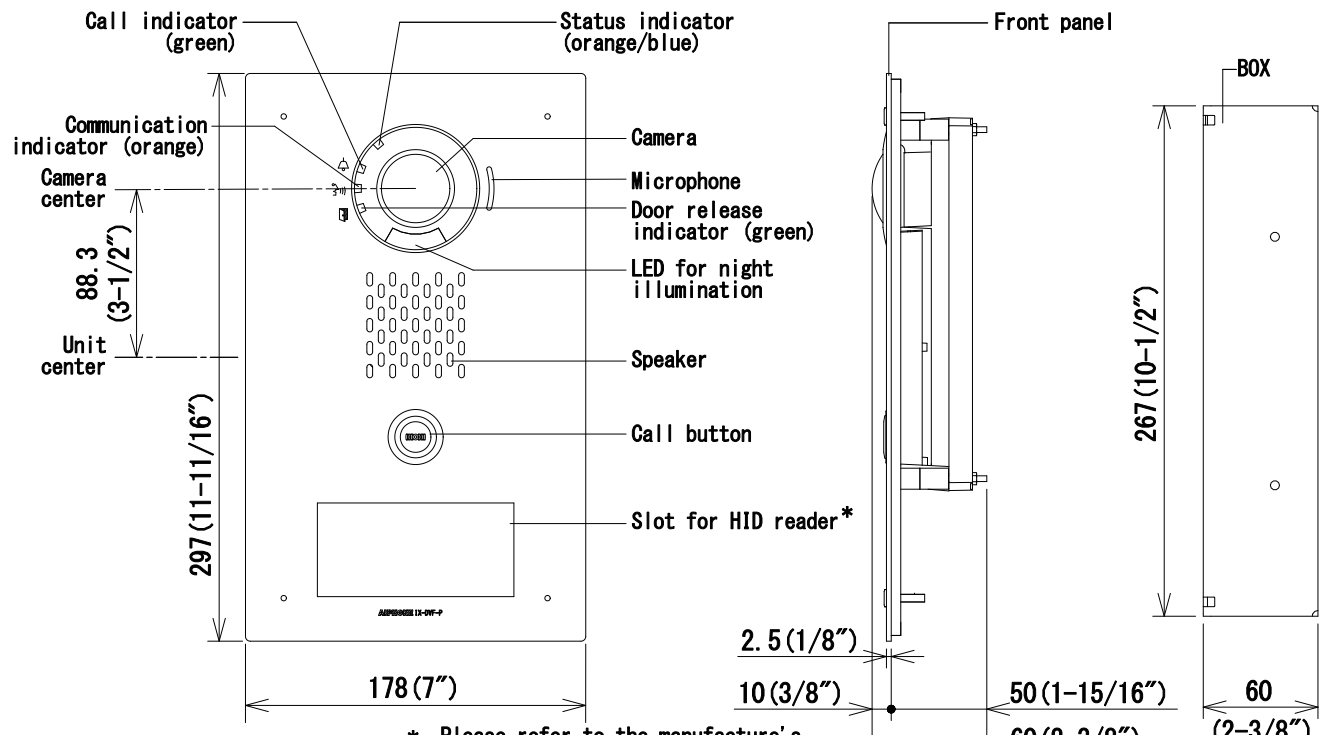

**SPECIFICATIONS**

\*. Please refer to the manufacture's specification for the details.

|                           |  |
|---------------------------|--|
| Power source              | Power-over-Ethernet (IEEE 802.3af/at Class 0) / 24V DC External power supply   |
| Current consumption       | Power-over-Ethernet<br>Standby: 55mA/Standby with continuous recording: 77mA<br>Maximum: 155mA<br>24V DC External power supply<br>Standby: 94mA/Standby with continuous recording: 140mA<br>Maximum: 300mA |
| Type of communication     | Hands-free: automatic voice switching  |
| Camera                    | 1/3-type color CMOS SXVGA 1280 x 960 (approx. 1.2 million pixels)  |
| Minimum illumination      | 5 lux  |
| LAN                       | Ethernet (10BASE-T, 100BASE-TX), Auto MDI/MDI-X-compatible   |
| Audio codec               | G.711 (μ-law, A-law), G.722  |
| Video codec               | H.264/AVC, Motion JPEG   |
| Protocol                  | IPv4, IPv6, TCP, UDP, SIP, HTTP, HTTPS, RTSP, RTP, RTCP, IGMP, MLD, SMTP, SFTP, DHCP, NTP, DNS   |
| Encryption method         | TLS1.0, TLS1.1, TLS1.2   |
| Packet delivery           | Unicast, Multicast   |
| Number of called stations | 20 stations  |
| Ambient temperature       | -40~+60°C (-40~+140° F)  |
| Mounting                  | Flush wall-mount   |
| Material                  | Front panel: stainless steel, vertical alignment finished/<br>Main unit: self-extinguishing ABS resin/ Box: SPCC 1.2   |
| Unit color                | Front panel: silver/ Main unit: black/<br>Box: black (Electrodeposition Coating)   |
| Weight                    | Unit: approx. 1.4kg (3.1 lbs) / Box: approx. 860g (1.9 lbs)  |
| IP rating                 | IP65   |
| IK rating                 | IK08   |
| Remarks                   | ONVIF Profile S support  |

|                           |                                |          |                |
|---------------------------|--------------------------------|----------|----------------|
| DESCRIPTION               | FIG. NAME                      | UNIT     | DATE           |
| <b>VIDEO DOOR STATION</b> | PRODUCT DRAWING/SPECIFICATIONS | mm       |                |
| MODEL NO.                 | FIG. NO.                       | REVISION |                |
|                           | PAGE                           | 1        |                |
|                           | 1/5                            |          | <b>AIPHONE</b> |