

RECOMMENDED FOR MAINTENANCE.

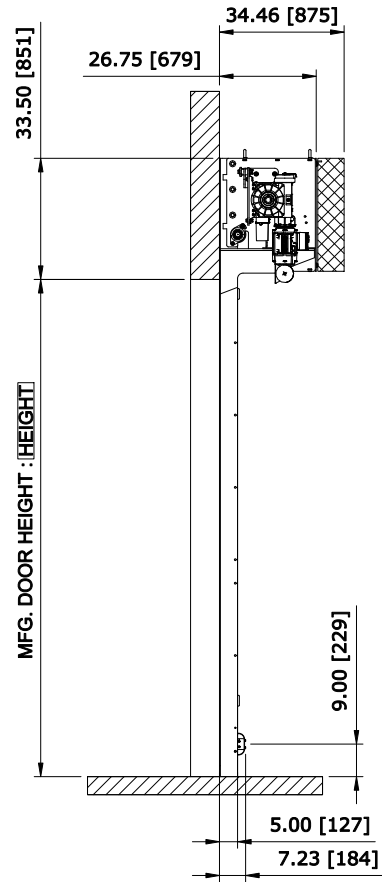

LEFT VIEW

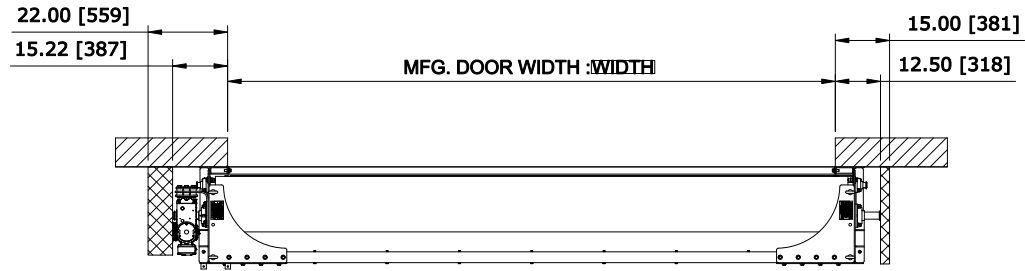

TOP VIEW

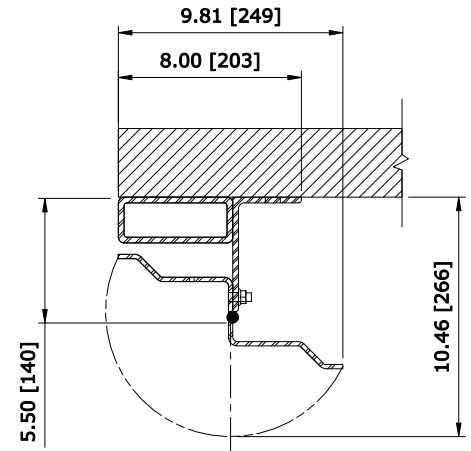

SECTION A-A

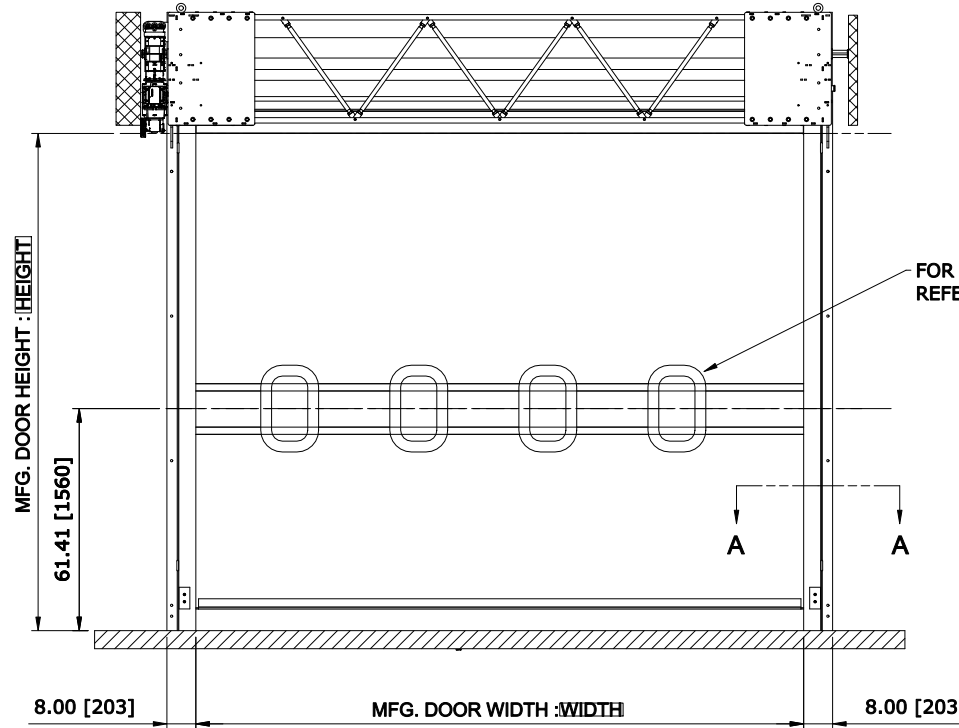

FRONT VIEW

FOR WINDOW CONFIGURATION REFER TO DOOR QUOTE.

33.5" HEADROOM UNBALANCED DIRECT DRIVE NO COVER LH

CONTROL PANEL:
CONTROLS

CUSTOMER:		SCALE = NOT TO SCALE	
LOCATION:		APPROVED BY:	APPROVED WITH CHANGES BY:
SALESMAN / DEALER:		DATE:	DATE:
DESCRIPTION: ULTRA TOUGH APPROVAL DRAWINGS			
DRAWING NO:		DESIGNER:	DATE:
8300T0064		J. Fisher	01/10/2017
Rev	Change	Date	Name