

LEGEND:

1. PRESSED STEEL FULLY WELDED BULLET RESISTANT FRAME.
2. WOOD VENEER BULLET RESISTANT DOOR.
3. VOIDS FILLED WITH INSULATION.
4. ARMOUR SHIELD TO UL752 LEVEL 3.
5. WOOD FACE VENEER. (BOTH SIDES) FACE VENEER TO BE: _____
6. ALL EDGES TO BE SOLID HARDWOOD INCLUDING MATCHING EDGES AT STILES. HARDWOOD EDGES TO BE FINISHED BY OTHERS.
7. ARMOUR SHIELD 1 1/16" MAXIMUM THICK GLASS LEVEL 3.

INDICATE IF GLASS IS TO BE:

- SUPPLIED BY OTHERS OR
- FACTORY SUPPLIED PREFINISHED.

NOTE:

IF GLASS IS SUPPLIED BY OTHERS FOR SITE INSTALLATION, CUSTOMER MUST ENSURE THAT THE GLASS HAS BEEN TESTED AND IS CERTIFIED UNDER UL 752.

GENERAL NOTES:

- ALL DOORS INCLUDE FACTORY PRE-MACHINING FOR HARDWARE
- ALL DOORS INCLUDE FACTORY SEALING AT EDGES.
- FACTORY PRE-FINISHING IS OPTIONAL SPECIFIED FACTORY FINISH TO BE: _____

NOTE:

WARNING FOR USE OF PLASTIC LAMINATE

PLASTIC LAMINATE DOORS ARE SENSITIVE TO HIGH MOISTURE ATMOSPHERE. DO NOT EXPOSE TO RELATIVE HUMIDITY ABOVE 40%.

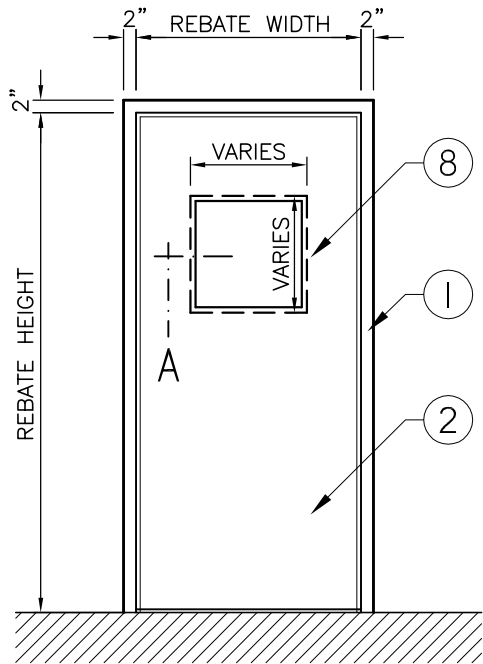

ELEVATION

NOTE: - THE SIZES SHOWN IN THE ELEVATION REFER TO THE DOOR CUTOUT SIZE.

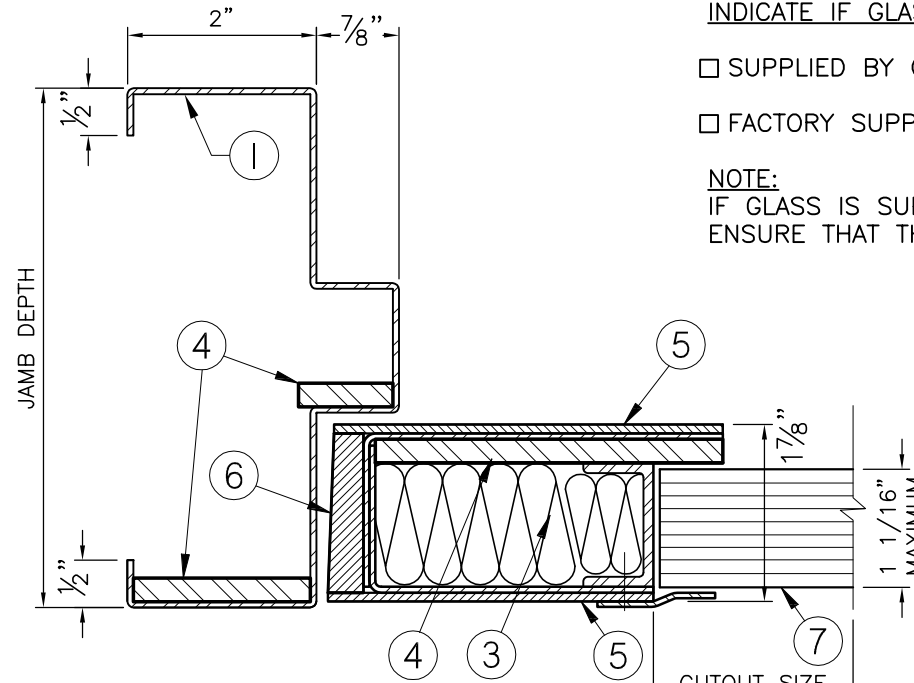

SECTION A

NOTE: FRAME MUST BE INSTALLED AT FINISHED FLOOR HEIGHT. (DO NOT EMBED IN FLOOR)



TYPICAL WOOD BULLET RESISTANT VISION LITE UL752 LEVEL 3

JOB NO: _____

SHEET: 1

OF: 1