

FRAME ELEVATION

NOTES:

1. 14ga GALVANEAL OVERSIZED FRAME.
2. WELDED SPLICE JOINT. JAMBS SHALL BE FACTORY WELDED, HEADER SHALL BE FIELD WELDED BY OTHERS.
3. 16ga GALVANEAL OVERSIZED DOOR.
4. 12ga FLAT OVERLAPPING ASTRAGAL:
 - IF LH/RH ASTRAGAL IS MOUNTED PUSH SIDE OF INACTIVE DOOR.
 - IF LHR/RHR ASTRAGAL IS MOUNTED PULL SIDE OF ACTIVE DOOR.
5. 16GA "TOP HAT" VERTICAL STIFFENERS REVERSAL OF STIFFENERS AT SEAM OF DOOR IF REQUIRED.
6. 16GA CHANNEL 3.00" FROM DOOR EDGES.
7. 18 GA INVERTED FLUSH CHANNEL.
8. 14 GA CHANNEL.

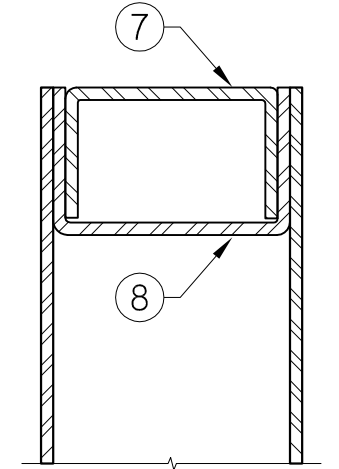

TOP/BOTTOM END CHANNELS

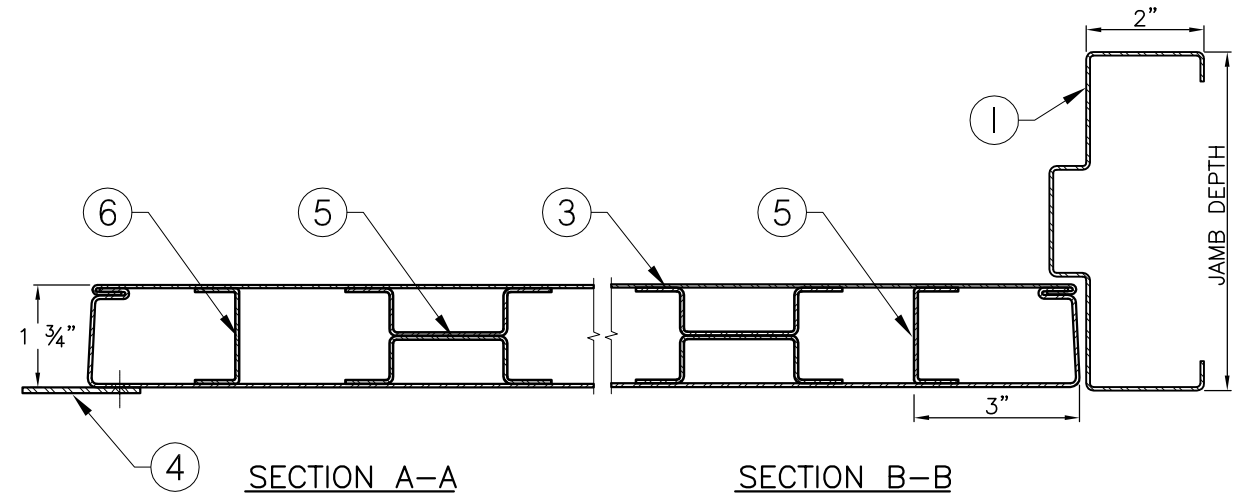

NOTE:

DOOR & FRAMES CAN BE FIRE RATED UP TO 180 MINUTES WHERE SIZE IS LESS THAN 50"-120". (100"-120")