

LEGEND:

1. 12GA. TO 18GA. GALVANEAL, FACTORY PRIME PAINTED.
2. FIBREGLASS INSULATED DOOR CORE.
3. PANEL CHANNEL REINFORCING AROUND ENTIRE PERIMETER OF THE RECESSED PANEL CUTOUT.
4. STIFFENERS FOR RECESSED PANEL.
5. 6" MINIMUM STILES AND RAILS.
6. 1/2" SQUARE BAR.

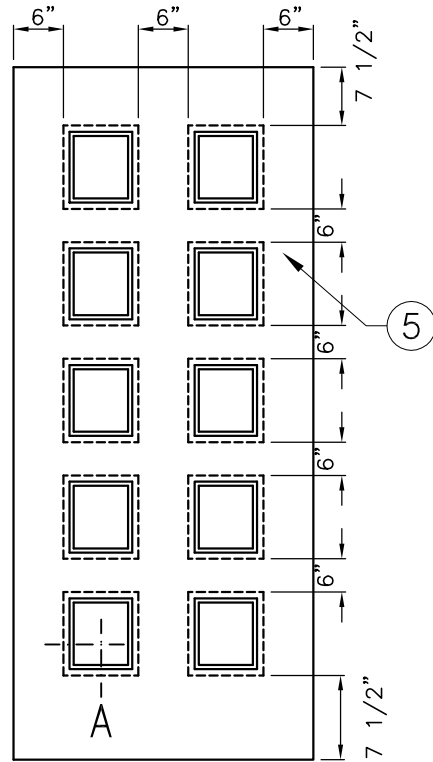

SIZES SHOWN REFER TO
DOOR CUTOUT SIZES

DOOR ELEVATION

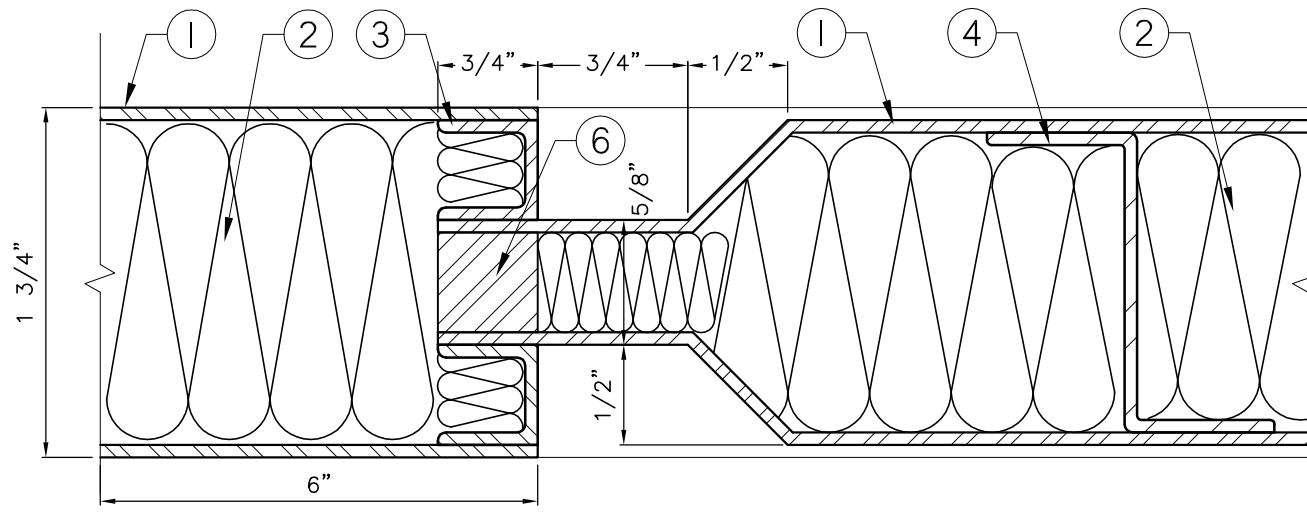

TYPICAL RECESSED PANEL SECTION 'A'

PRODUCT OPTIONS

- TACK & FILLED "SEAMLESS EDGE SEAMS"
- FLUSH CLOSED TOP CAP
- FLUSH CLOSED BOTTOM CAP
- FIRE LABEL :
- 20 MINUTE
- 45 MINUTE
- 90 MINUTE