

**LEGEND:**

1. 12GA. TO 18GA. GALVANEAL DOOR & PANEL, FACTORY PRIME PAINTED.
2. FIBREGLOSS INSULATED CORE.
3. VISION CHANNEL REINFORCING AROUND ENTIRE PERIMETER OF THE VISION CUTOUT.
4. PANEL CHANNEL REINFORCING AROUND ENTIRE PERIMETER OF THE RECESSED PANEL CUTOUT.
5. REMOVABLE GLAZING BEAD.
6. EXTENDED DOOR SKIN TO ACT AS FIXED GLAZING STOP. FIXED STOP TO BE ON THE LOCK CYLINDER SIDE OF THE DOOR.
7. GLASS BY OTHERS.
8. STIFFENERS FOR RECESSED PANEL.
9. 6" MINIMUM STILES AND RAILS.
10. 1/2" SQUARE BAR.

**PRODUCT STANDARDS**

DOOR PANEL SIZES AND QUANTITY ARE AT THE ARCHITECTS DESCRETION.

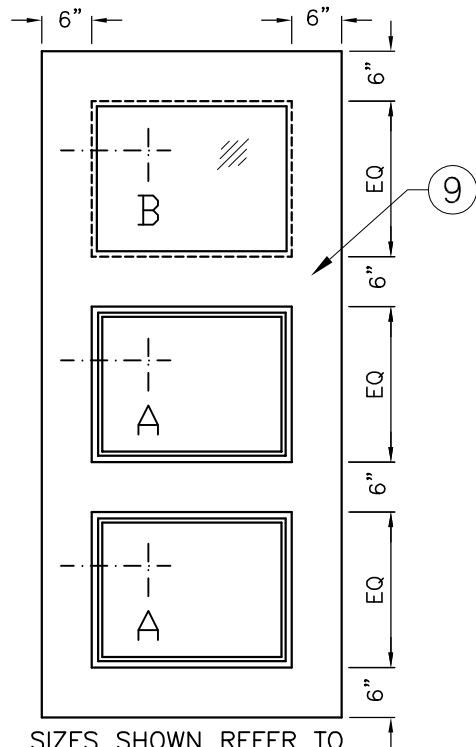

SIZES SHOWN REFER TO DOOR CUTOUT SIZES

**DOOR ELEVATION**

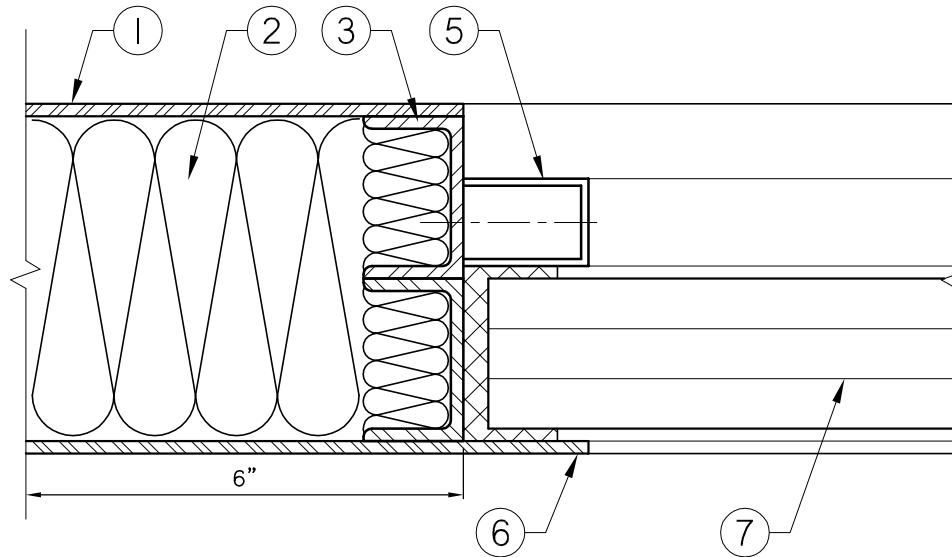

**TYPICAL VISION LITE SECTION 'B'**

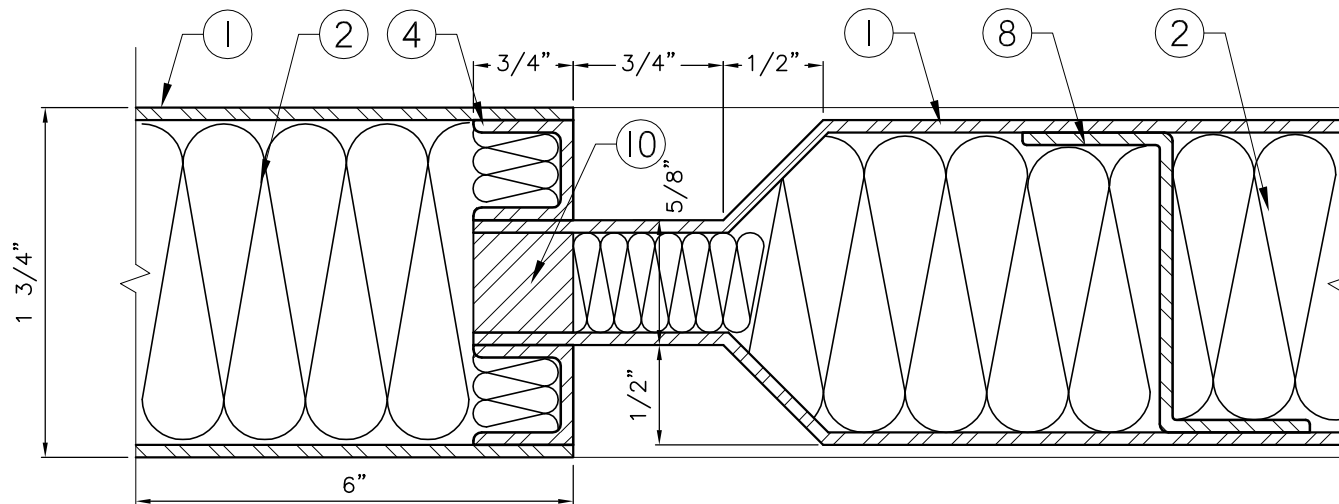

**TYPICAL RECESSED PANEL SECTION 'A'**

**PRODUCT OPTIONS**

- TACK & FILLED "SEAMLESS EDGE SEAMS
- VISION LITE KIT(S) REQUIRED (SEE DOOR ELEVATION)  
GLASS THICKNESS: \_\_\_\_\_  
GLAZING BY: \_\_\_\_\_
- FLUSH CLOSED TOP CAP
- FLUSH CLOSED BOTTOM CAP
- FIRE LABEL :
- 20 MINUTE
- 45 MINUTE
- 90 MINUTE