

## PRODUCTS STANDARDS:

FRAMES SHALL BE TEMPLATED, REINFORCED AND DRILLED & TAPPED FOR MORTISED HARDWARE. ALL REINFORCING SHALL BE THE SAME MATERIAL AND FINISH AS THE FRAME. DRILLING & TAPPING FOR SURFACE APPLIED HARDWARE SHALL BE BY OTHERS. FRAMES SHALL BE SHIPPED WITH TEMPORARY SPREADERS FOR SUPPORT DURING SHIPPING. THESE ARE NOT TO BE A SUBSTITUTE FOR SQUARING OR PLUMBING OF FRAMES DURING INSTALLATION. FRAMES SHALL BE SHIPPED WITH BUMPERS TO BE MOUNTED ON STOPS (3 ON A SINGLE & 2 ON DOUBLES), WALL ANCHORS, AND FLOOR CLIPS. FLOOR CLIPS WILL BE OMITTED WITH EXISTING WALL ANCHORS.

## PRODUCTS OPTIONS:

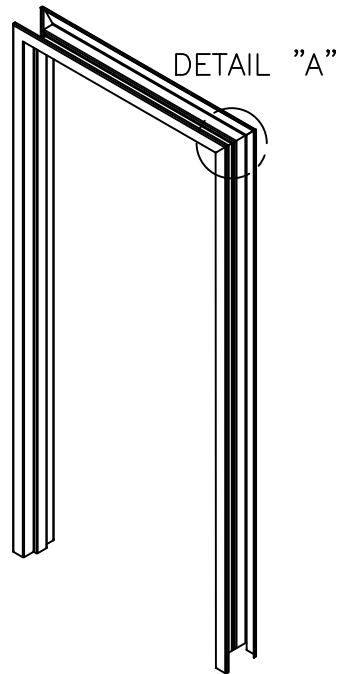

### FRAME

#### STAINLESS STEEL MATERIALS AND FINISHES<sup>1</sup>

##### MATERIALS

- o TYPE 304 STAINLESS
- o TYPE 316 STAINLESS

##### THICKNESSES

- o 12 GA.
- o 14 GA.
- o 16 GA.

##### FINISHES<sup>2</sup>

- o 2B, NOT PAINTED
- o #8 XL BUFF
- o #4
- o #8 SUPREME
- o #6
- o XL BLEND S
- o #7
- o XL SUEDE

##### CORNER CONSTRUCTION

- o BUTT JOINT<sup>3</sup>
- o MITERED JOINT<sup>4</sup>

<sup>1</sup>MATERIALS AND FINISHES ARE TYPICAL. CONSULT AMBICO FOR ADDITIONAL OPTIONS.

<sup>2</sup>SOME FINISHES MAY NOT BE POSSIBLE BASED ON HARDWARE. CONSULT AMBICO FOR INFORMATION.

<sup>3</sup>PLUG WELDED VIA INTERNAL PLATES.

<sup>4</sup>FULLY WELDED FOR STAINLESS STEELS WITH GRAINED FINISHES. MECHANICALLY FASTENED FOR ALL OTHER FINISHES.

##### GENERAL NOTES

– ALL GRAINED FINISHES SHALL HAVE VERTICAL GRAIN IN JAMBS AND VERTICAL MULLIONS AND HORIZONTAL GRAIN IN HEADS, SILLS AND HORIZONTAL MULLIONS. ALL FACE WELDS SHALL BE GROUND AND RE-GRAINED/BUFFED TO A VISIBLE HAIRLINE AT MITER. INTERSECTING MULLIONS, MULLIONS AND PERIMETERS, CONNECTIONS BETWEEN UNEQUAL FACE DIMENSIONS AND ALL POLISHED MIRROR FINISHES SHALL HAVE VISIBLE BUTT JOINT CONNECTIONS

– WELDED FRAMES WITH ANY FACE GREATER THAN 2" MUST BE 14 GA OR THICKER

**ISOMETRIC**  
3/4" = 1'-0"

DRAWING TITLE:

**STAINLESS STEEL FRAME SPECIFICATION SHEET 1 OF 2**

DATE: MARCH 7, 2017

DRAWN BY: TWB

REVISION: 0



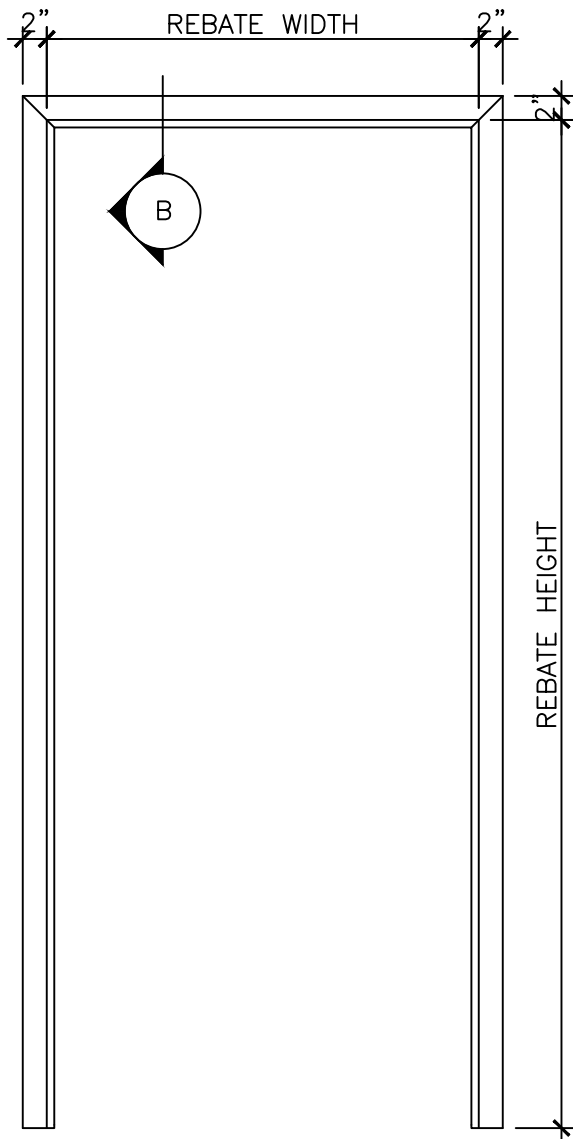

**ELEVATION**  
3/4" = 1'-0"

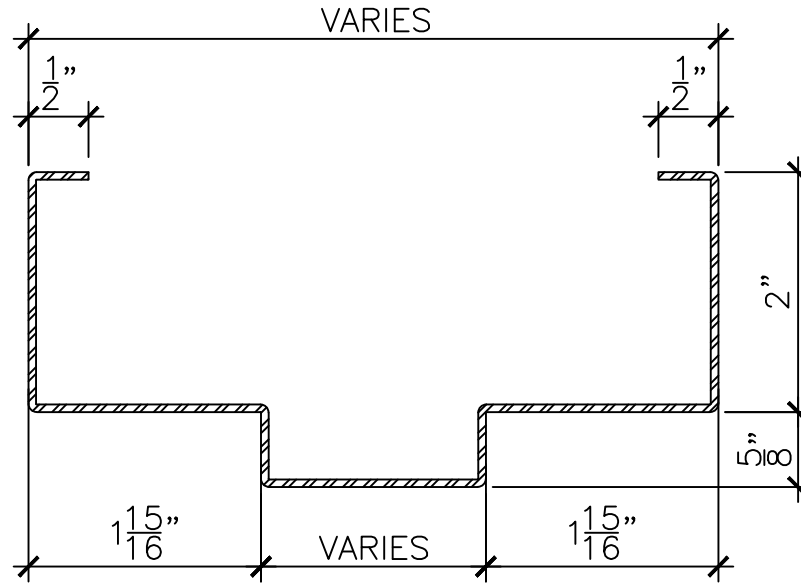

**DOUBLE REBATE DETAIL "B"**  
1"-0" = 1'-0"

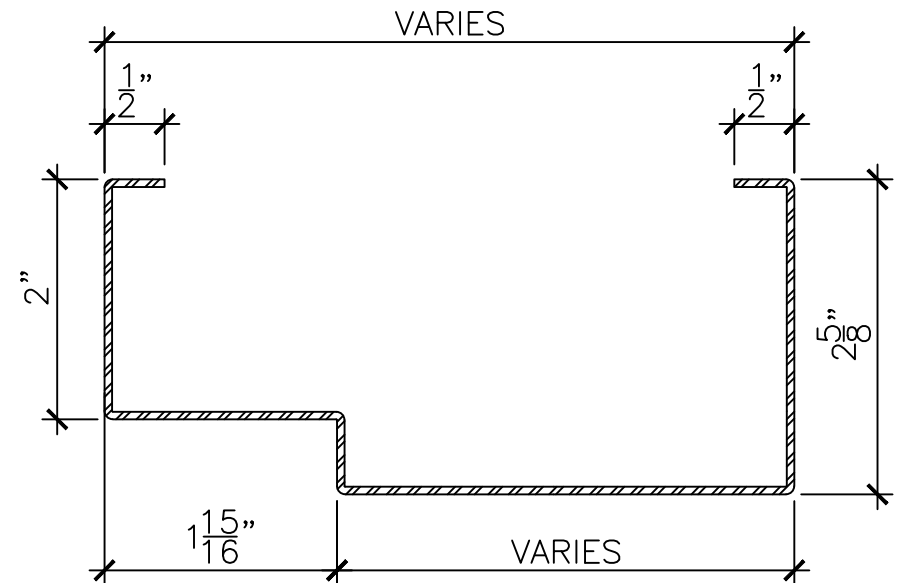

**SINGLE REBATE DETAIL "B"**  
1"-0" = 1'-0"

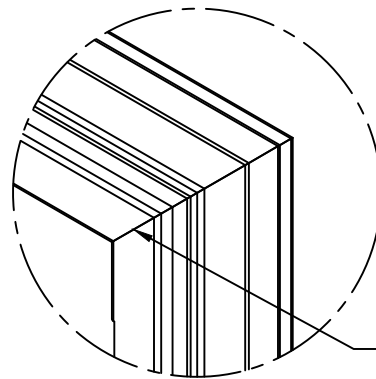

FULLY WELDED AND  
BUFFED FINISHED CORNER

**MITERED JOINT DETAIL "A"**  
1"-0" = 1'-0"

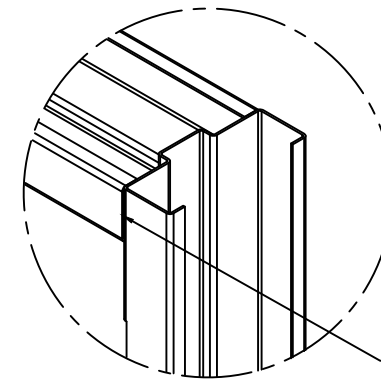

WELDED VISIBLE  
BUTT JOINT CORNER

**BUTT JOINT DETAIL "A"**  
1"-0" = 1'-0"



DRAWING TITLE:  
**STAINLESS STEEL FRAME SPECIFICATION SHEET 2 OF 2**

DATE: MARCH 7, 2017  
DRAWN BY: TWB  
REVISION: 0