

SECTION A - TYPICAL FRAME

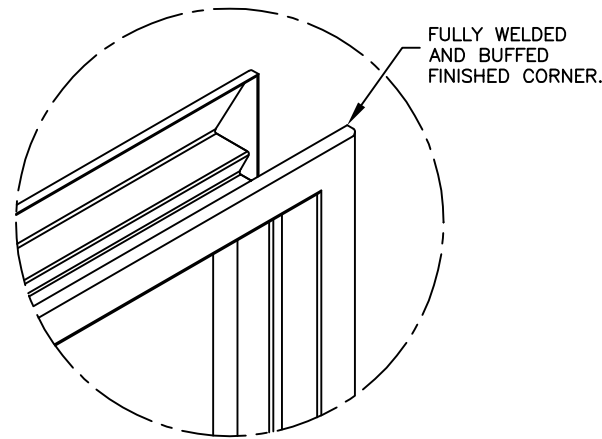

DETAIL 'B': MITERED CORNER OPTION

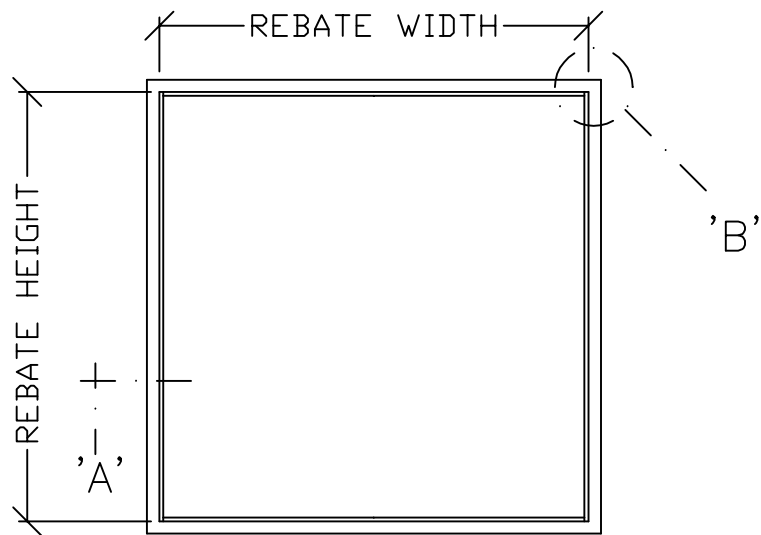

ELEVATION

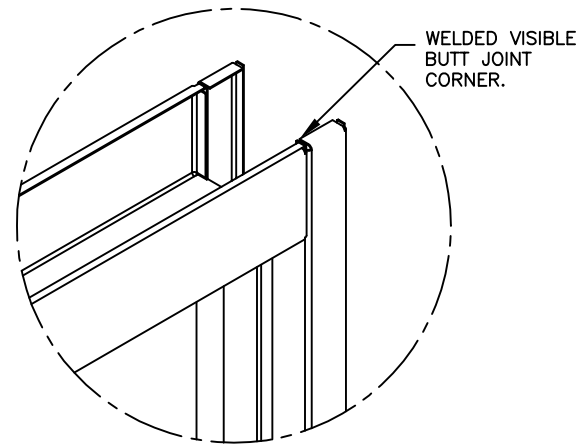

DETAIL 'B': BUTT JOINT OPTION

GLAZING BY:
GLAZING THICKNESS:

STEEL TYPE AND FINISH SHALL BE:

- ___ TYPE 304
- ___ TYPE 316 (HIGH CORROSION RESISTANCE)
- ___ 2B (MILL FINISH)
- ___ #4 (SATIN FINISH)
- ___ #8 (MIRROR FINISH)

MANY OPTIONAL FINISHES ARE AVAILABLE, CONSULT FACTORY. SOME EXAMPLES ARE ETCHED, COLORED, OR PATTERNED FINISHES.

ALL GRAINED FINISHES SHALL HAVE VERTICAL GRAIN IN JAMBS AND VERTICAL MULLIONS AND HORIZONTAL GRAIN IN HEADS, SILLS, AND HORIZONTAL MULLIONS. ALL FACE WELDS SHALL BE GROUND AND RE-GRAIN BUFFED TO A VISIBLE HAIRLINE AT MITER. INTERSECTING MULLIONS, MULLIONS AND PERIMETERS, CONNECTIONS BETWEEN UNEQUAL FACE DIMENSIONS, AND ALL POLISHED MIRROR FINISHES SHALL HAVE VISIBLE BUTT JOINT CONNECTIONS.

TYPICAL STAINLESS STEEL BORROWED LITE FRAME

JOB NO:

SHEET:

OF: