

1: GLAZING MATERIAL

	INNER	OUTER
ACRYLIC DOME	<input type="checkbox"/>	<input type="checkbox"/>
POLYCARBONATE DOME	<input type="checkbox"/>	<input type="checkbox"/>

2: GLAZING COLOR

CLEAR	<input type="checkbox"/>	<input type="checkbox"/>
BRONZE	N/A	<input type="checkbox"/>
WHITE	<input type="checkbox"/>	<input type="checkbox"/>
OTHER _____		

3: FRAME FINISH

MILL	<input type="checkbox"/>
BRONZE ANODIZED	<input type="checkbox"/>
CLEAR ANODIZED	<input type="checkbox"/>
CUSTOM COLOR _____	

4: PYRAMID PITCH (OPTIONAL)

22 DEGREE (1/2 WIDTH X .414)	<input type="checkbox"/>
30 DEGREE (1/2 WIDTH X .577)	<input type="checkbox"/>
40 DEGREE (1/2 WIDTH X .839)	<input type="checkbox"/>

5: BAY CONFIGURATION

OF BAYS WIDTH = _____

OF BAYS LENGTH (SLOPE) = _____

*PROVIDE THE OVERALL OUTSIDE DIMENSION OF THE FINISHED CURB.

*GRID SYSTEMS SHIPPED AS MULTIPLE TANDEM SYSTEMS FOR PARTIAL FIELD ASSEMBLY.

*STRUCTURAL MULLION COVER & GUTTER ASSEMBLY SHIPPED LOOSE.

*STRUCTURAL MULLION MIN SLOPE = 1/12.

*#5 BAY CONFIGURATION MUST BE COMPLETED.

*BAY DETAIL AVAILABLE UPON REQUEST.

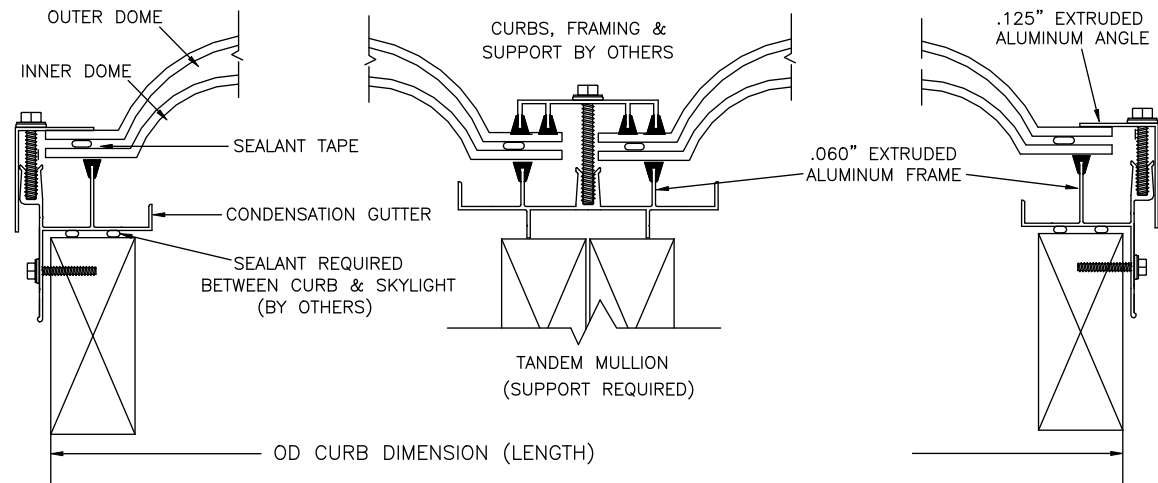
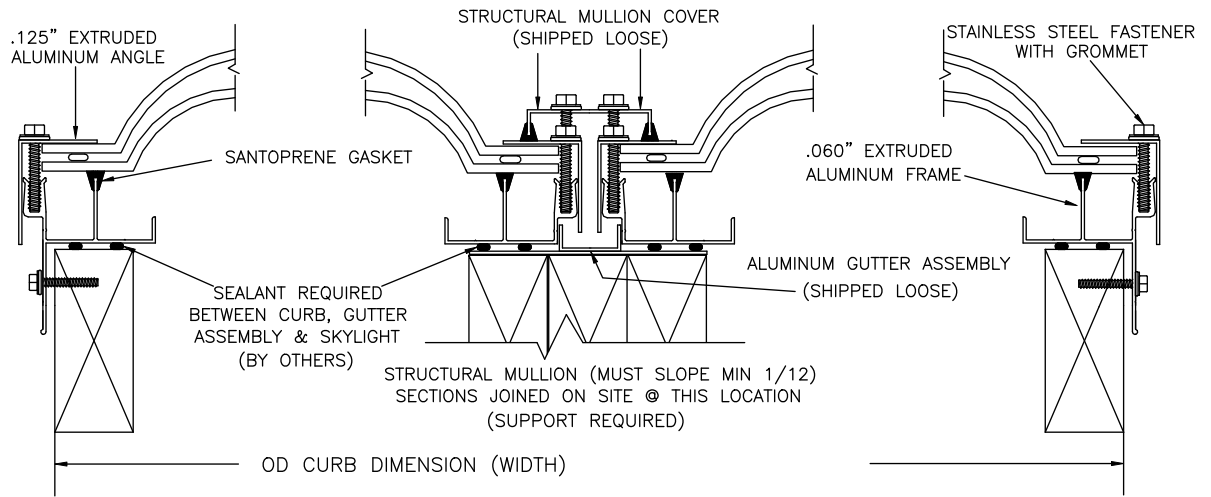

GRID SYSTEM CURB MOUNT
MODEL (GSCM)



AMERICAN SKYLIGHTS

Phone: 855.772.7401 Fax: 855.445.7282