

**NOTE !**

STILE TO BE OF #20 GA. VENEER  
 STEEL CONSTRUCTION LAMINATED  
 TO A HONEYCOMB CORE AND COVERED  
 EXTERNALLY WITH HIGH PRESSURE  
 LAMINATED PLASTIC.

TYPE P.L.-C.S. STILE FASTENING ASSEMBLY

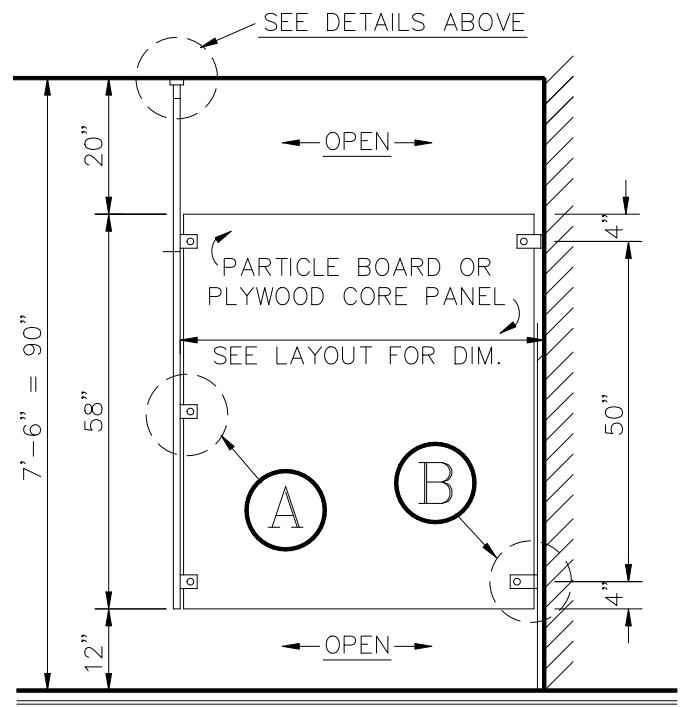
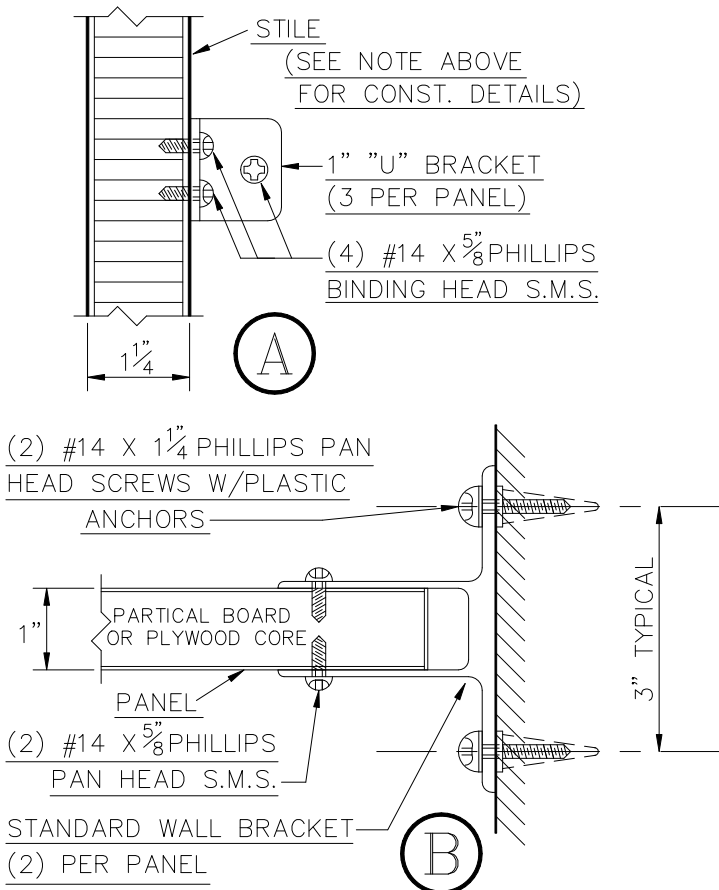

TYPE P.L.-C.S. STILE & PANEL INSTALLATION