

NOTES:

- 1.) Post size depends on fence height and wind loads. See *MONTAGE PLUS™* specifications for post sizing chart.
- 2.) Forth rail optional.
- 3.) 7' & 8' Heights will require a 14ga Picket and 14ga Post.

RAKING DIRECTIONAL ARROW

Welded panel can be raked 30" over 8' with arrow pointing down grade.

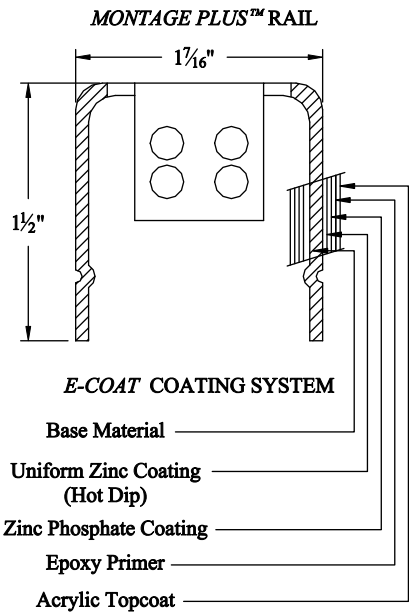

E-COAT COATING SYSTEM

- Base Material
- Uniform Zinc Coating (Hot Dip)
- Zinc Phosphate Coating
- Epoxy Primer
- Acrylic Topcoat

PROFUSION™ WELDING PROCESS

No exposed welds,
Good Neighbor profile - Same appearance on both sides

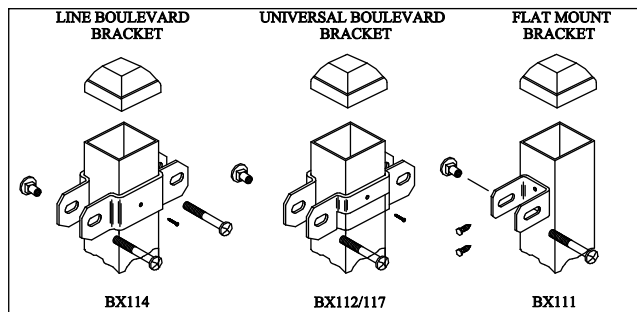
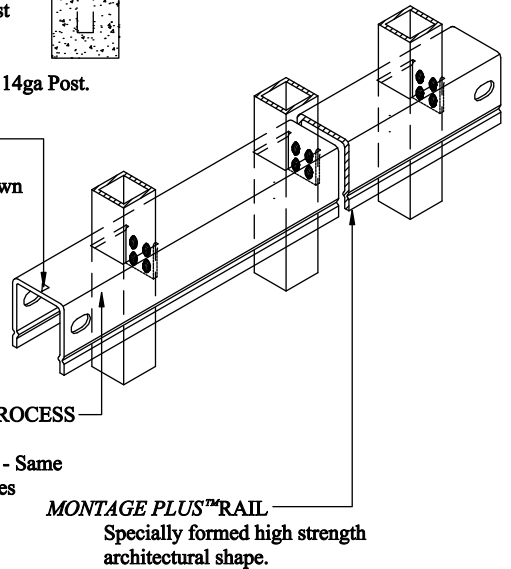

**COMMERCIAL STRENGTH WELDED STEEL PANEL
PRE-ASSEMBLED**

Title: **MONTAGE COMMERCIAL MAJESTIC 3/4-RAIL**

DR: RTM	SH . 1 of 1	SCALE: DO NOT SCALE
CK: ME	Date 6/2/08	REV: c



AMERISTAR™

1555 N. Mingo
Tulsa, OK 74116
1-888-333-3422
www.ameristarfence.com