

RAKING DIRECTIONAL ARROW
 Welded panel can be raked 30" over 8' with arrow pointing down grade.

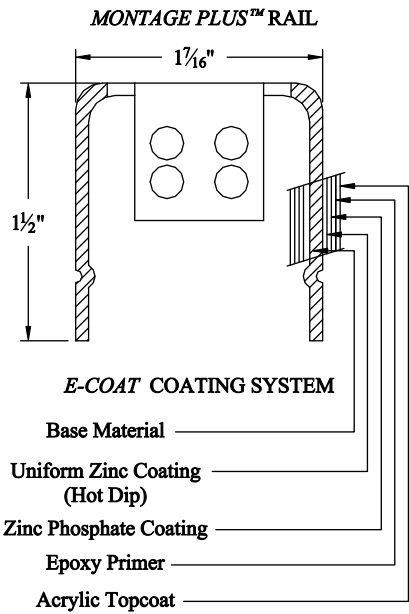

PROFUSION™ WELDING PROCESS
 No exposed welds,
 Good Neighbor profile - Same appearance on both sides

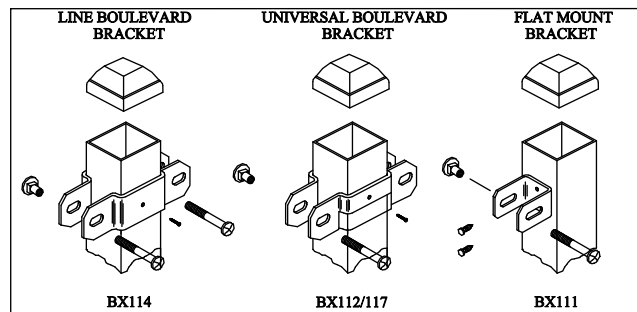
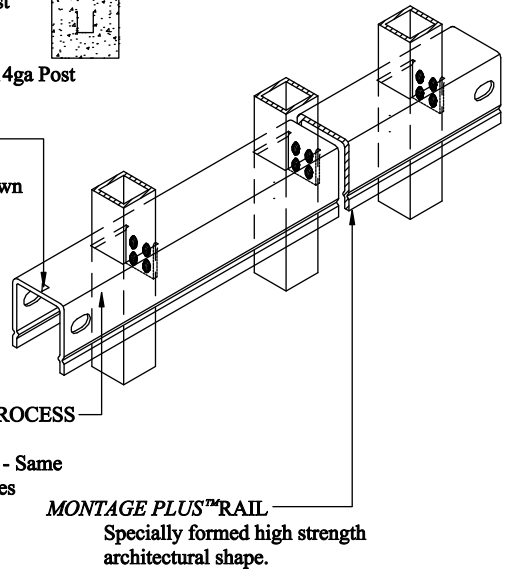

COMMERCIAL STRENGTH WELDED STEEL PANEL
PRE-ASSEMBLED

Title: **MONTAGE COMMERCIAL GENESIS 3/4-RAIL**

DR: RTM SH . 1 of 1 SCALE: DO NOT SCALE

CK: ME Date 6/2/08 REV: b



AMERISTAR™

1555 N. Mingo
 Tulsa, OK 74116
 1-888-333-3422
 www.ameristarfence.com