

NOTES:

- 1.) Post size depends on fence height and wind loads. See AEGIS Plus™ post sizing chart.
- 2.) Panels also available for 6' on center post spacing
- 3.) Additional heights available on request
- 4.) Third rail optional (Required with rings, See Detail).

RING OPTION

Held in place with upper and lower internal retaining rods to eliminate unsightly external fasteners.

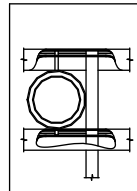

PANEL BRACKET

Specially designed two-point connection ensures fixity of rail ends for increased strength.

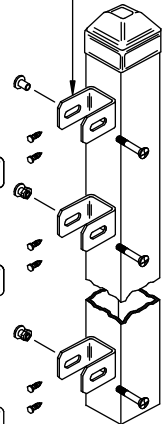

INTERNAL RETAINING ROD

Variable pitch connection system for ease of installation, high angle bias ability and elimination of unsightly external fasteners.

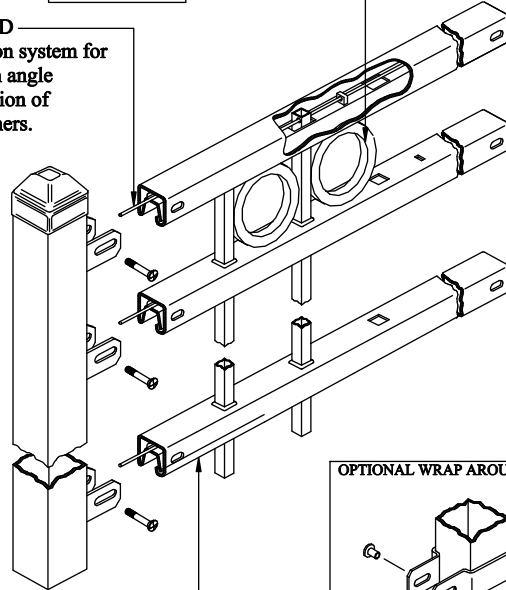

OPTIONAL WRAP AROUND BRACKET

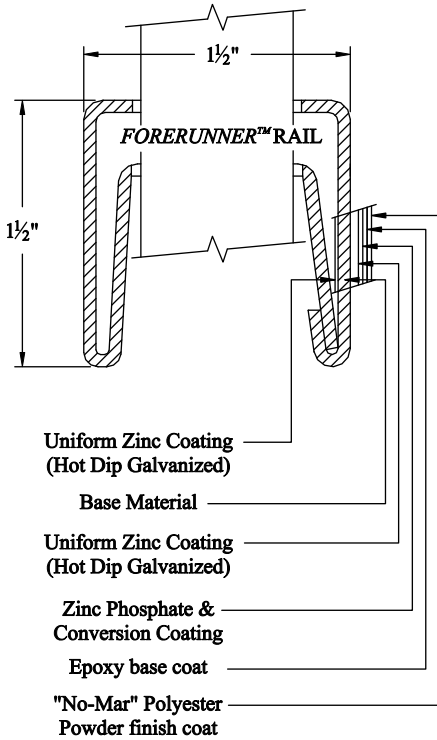
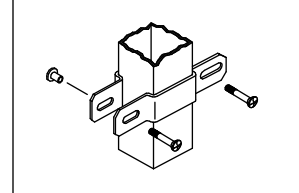

- Uniform Zinc Coating (Hot Dip Galvanized)
- Base Material
- Uniform Zinc Coating (Hot Dip Galvanized)
- Zinc Phosphate & Conversion Coating
- Epoxy base coat
- "No-Mar" Polyester Powder finish coat

FORERUNNER™ RAIL
Double-walled "U"-Channel
Specially formed high strength architectural shape.

COMMERCIAL STRENGTH STEEL

Title: **AEGIS PLUS MAJESTIC 2/3-RAIL W/RING OPTION**

DR: CI	SH. 1 of 1	SCALE: DO NOT SCALE
CK: PB	Date 7/20/09	REV: d



AMERISTAR®

1555 N. Mingo
Tulsa, OK 74116
1-888-333-3422
www.ameristarfence.com