

NOTES:

- 1.) Post size depends on fence height and wind loads. See *AEGIS Plus™* post sizing chart.
- 2.) Panels also available for 6' on center post spacing
- 3.) Additional heights available on request. Post height will change with Adornment installation.
- 4.) Third rail optional (Required with rings, See Detail).

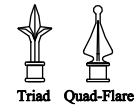

③ Adornment Options

RING OPTION

Held in place with upper and lower internal retaining rods to eliminate unsightly external fasteners.

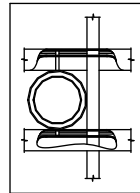

INTERNAL RETAINING ROD

Variable pitch connection system for ease of installation, high angle bias ability and elimination of unsightly external fasteners.

PANEL BRACKET

Specially designed two-point connection ensures fixity of rail ends for increased strength.

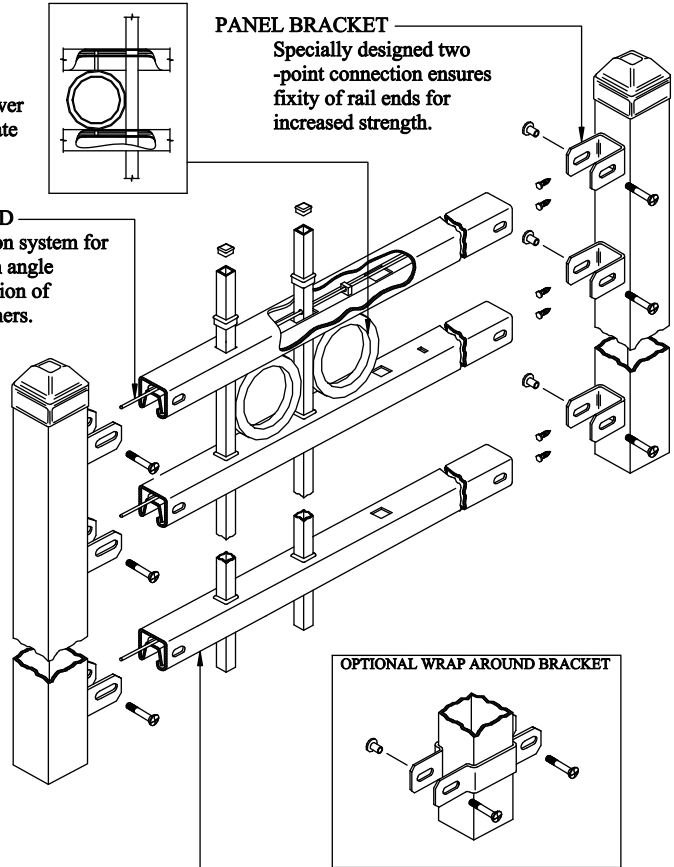

FORERUNNER™ RAIL

Double-walled "U"-Channel Specially formed high strength architectural shape.

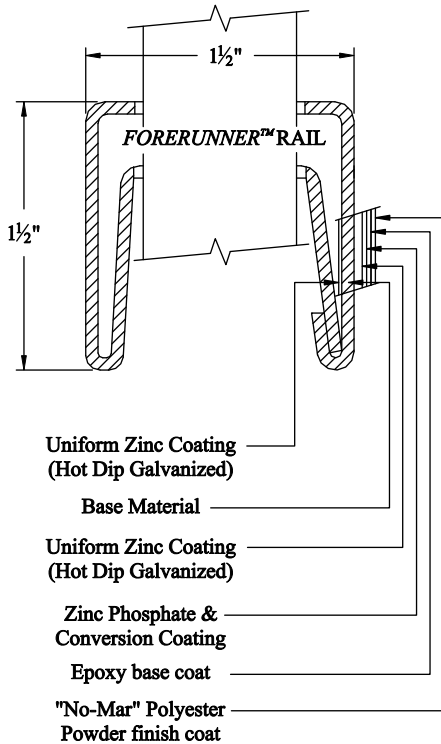

Uniform Zinc Coating (Hot Dip Galvanized)

Base Material

Uniform Zinc Coating (Hot Dip Galvanized)

Zinc Phosphate & Conversion Coating

Epoxy base coat

"No-Mar" Polyester Powder finish coat

COMMERCIAL STRENGTH STEEL

Title: **AEGIS PLUS GENESIS 2/3-RAIL W/RING OPTION**

DR: CI SH. 1 of 1 SCALE: DO NOT SCALE

CK: PB Date 7/20/09 REV: d



AMERISTAR®

1555 N. Mingo
Tulsa, OK 74116
1-888-333-3422
www.ameristarfence.com