

NOTES:

- 1.) Post size depends on fence height and wind loads. See *AEGIS II™* post sizing chart.
- 2.) Panels also available for 6' on center post spacing
- 3.) Additional heights available on request
- 4.) Third rail optional.

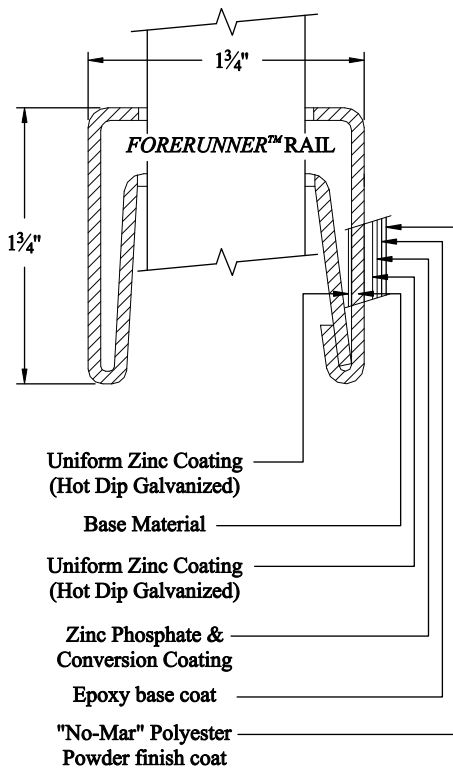

PANEL BRACKET

Specially designed two-point connection ensures fixity of rail ends for increased strength.

INTERNAL RETAINING ROD

Variable pitch connection system for ease of installation, high angle bias ability and elimination of unsightly external fasteners.

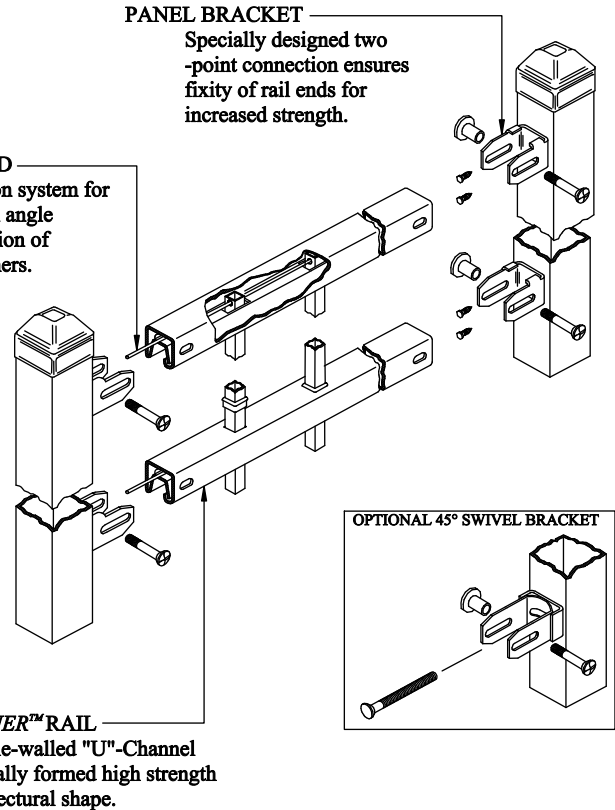

INDUSTRIAL STRENGTH STEEL

Title: AEGIS II MAJESTIC 2/3-RAIL		
DR: CI	SH . 1 of 1	SCALE: DO NOT SCALE
CK: PB	Date 7/20/09	REV: a



AMERISTAR®

1555 N. Mingo
Tulsa, OK 74116
1-888-333-3422
www.ameristarfence.com