

**NOTES:**

- 1.) Post size depends on fence height and wind loads. See AEGIS II post sizing chart.
- 2.) Additional heights available on request
- 3.) Third rail optional.
- 4.) Panels also available for 6' on center post spacing.

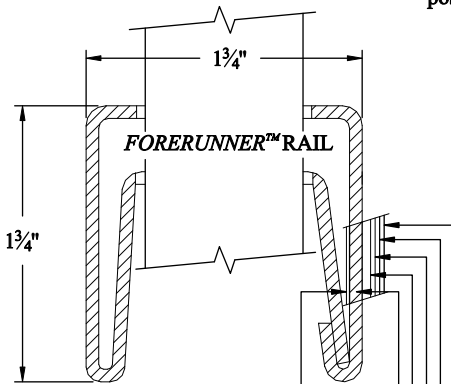

Uniform Zinc Coating (Hot Dip Galvanized)

Base Material

Uniform Zinc Coating (Hot Dip Galvanized)

Zinc Phosphate & Conversion Coating

Epoxy base coat

"No-Mar" Polyester Powder finish coat

**PANEL BRACKET**

Specially designed two-point connection ensures fixity of rail ends for increased strength.

**INTERNAL RETAINING ROD**

Variable pitch connection system for ease of installation, high angle bias ability and elimination of unsightly external fasteners.

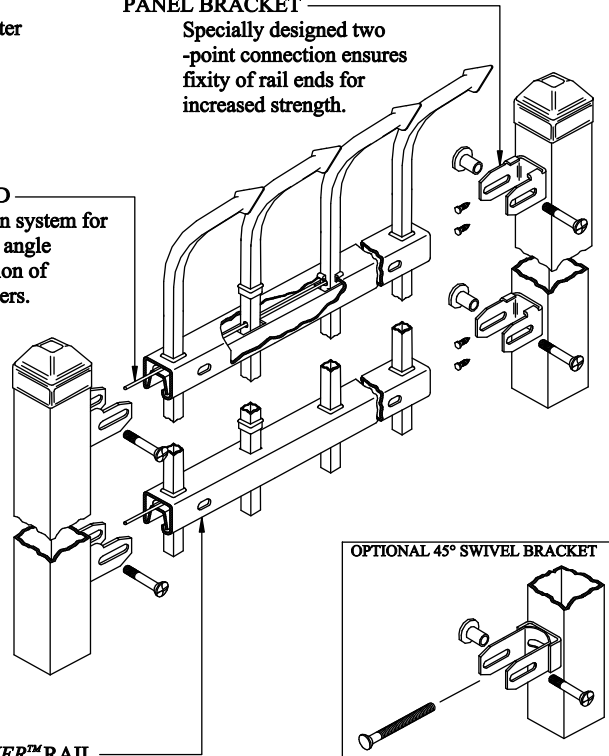

**FORERUNNER™ RAIL**

Double-walled "U"-Channel Specially formed high strength architectural shape.

**OPTIONAL 45° SWIVEL BRACKET**

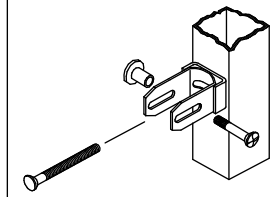

**INDUSTRIAL STRENGTH STEEL**

Title: <b>AEGIS II INVINCIBLE 2/3-RAIL</b>			
DR: CI	SH. 1 of 1	SCALE: DO NOT SCALE	
CK: PB	Date 7/20/09	REV: b	



**AMERISTAR®**

1555 N. Mingo  
Tulsa, OK 74116  
1-888-333-3422  
www.ameristarfence.com