

**NOTES:**

- 1.) Post size depends on fence height and wind loads. See *ECHELON PLUS™* post sizing chart.
- 2.) Panels also available for 6' on center post spacing
- 3.) Additional heights available on request. Some heights noted require a third and/or fourth rail.
- 4.) Third and Fourth rail optional.



Ring

**Adornment Options**

**PANEL BRACKET**

Boulevard design makes stronger rail to post connection by wrapping completely around bracket

**INTERNAL RETAINING ROD**

Variable pitch connection system for ease of installation, high angle bias ability and elimination of unsightly external fasteners.

**REINFORCED POST**

Internal rib increases against wind loading as well as other horizontally applied forces (Only on 2 1/2" aluminum posts).

**OPTIONAL FLAT MOUNT BRACKET**

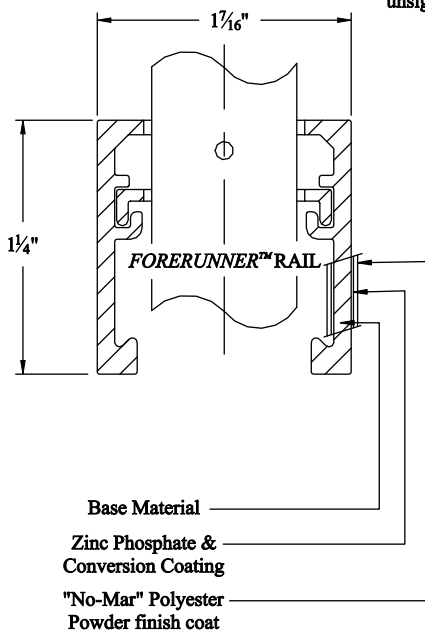
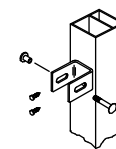

**INTERIOR GUIDE CHANNEL**  
Channel forms lower limit of raceway for retaining rod and allows for high angle bias ability.

**FORERUNNER™ RAIL**  
"U"-Channel specially formed high strength architectural shape.

Base Material  
Zinc Phosphate & Conversion Coating  
"No-Mar" Polyester Powder finish coat

Title: **ECHELON PLUS GENESIS 2/3/4-RAIL**

DR: CI	SH . 1 of 1	SCALE: DO NOT SCALE
CK: PB	Date 5/12/09	REV: a



**AMERISTAR®**

1555 N. Mingo  
Tulsa, OK 74116  
1-888-333-3422  
www.ameristarfence.com