

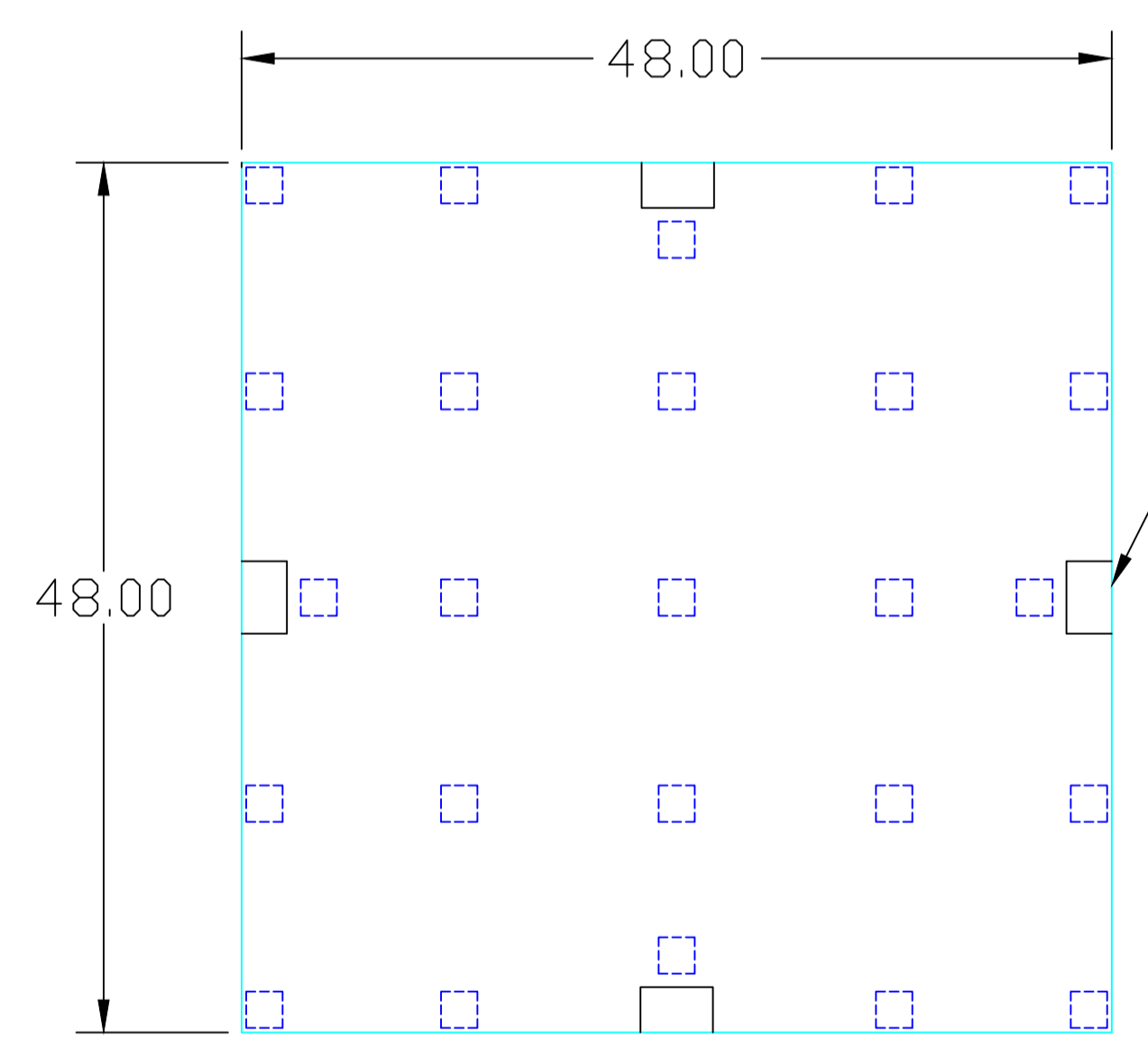

96" X 48" [2428 X 1219mm] STAGE PANEL



48" X 48" [1219 X 1219mm] STAGE PANEL

NOTES:

* OVERALL FLOOR THICKNESS DEPENDS ON WHAT SURFACE IS USED.

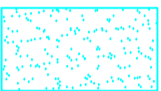
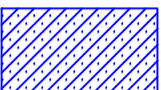
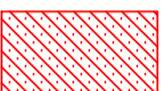
-  CHOICE OF VINYL PERFORMANCE SURFACE: HARLEQUIN CASCADE .080", STUDIO .120", STANDFAST .120", FIESTA .080", STUDIO B .120", REVERSIBLE .050", REVERSIBLE PRO .060"
-  HARDWOOD CORE, .750" THICK
-  PROGRESSIVE RESISTANCE SUSPENSION: RUBBER SUSPENSION PADS, THICKNESS .75", DENSITY: PROPRIETARY.
-  HARDBOARD .125" THICK.

DUAL-DUROMETER SUSPENSION TOWERS (REF)

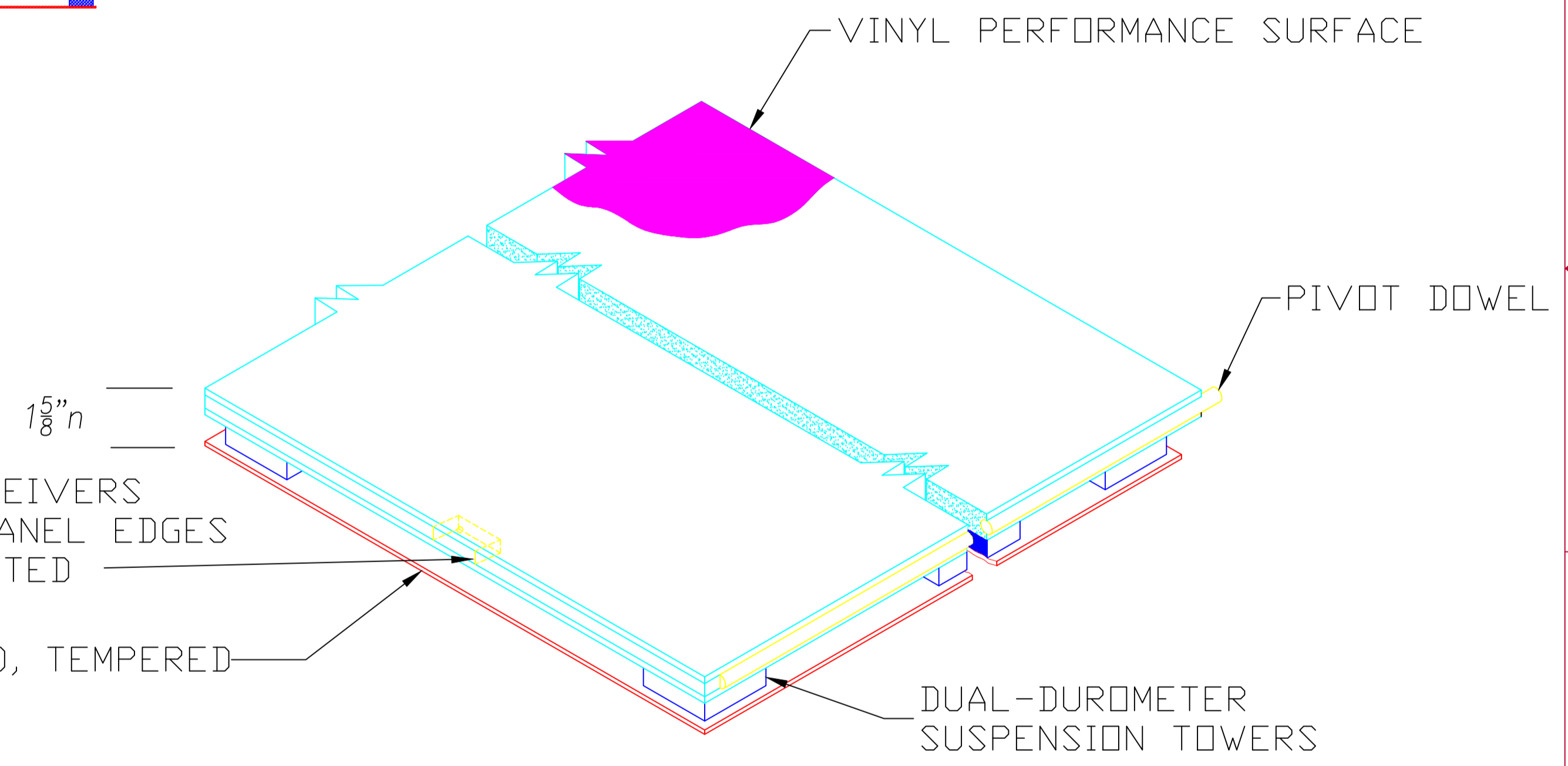

ISOMETRIC CUTAWAY VIEW OF FLOOR PANEL

AMERICAN HARLEQUIN CORPORATION
 1531 GLEN AVENUE
 MOORESTOWN, NJ 08057
 856-234-5505 FAX: 856-231-4403
 contact@harlequinfloors.com
 www.harlequinfloors.com

DRAWING TITLE:
 HARLEQUIN LIBERTY
 LATCH LOC TM STAGE PANELS

DRAWING NUMBER:	SCALE	REV.
C-204	12"=1'-0"	0