

**GUIDE DIMENSIONS**

GUIDE TYPE	A'	B'	C'	D'	E'	F'	G'
2	2 5/8"	3 7/8"	5 1/8"	1 1/4"	2 13/16"	4"	1 1/4"
3	2 5/8"	4 3/4"	5 5/8"	1 1/4"	2 13/16"	4 3/8"	1 1/4"
4	2 5/8"	4 3/4"	5 5/8"	1 1/4"	2 7/8"	4 3/4"	1 1/4"
2(W/L)	3"	4 1/4"	5 1/2"	1 5/8"	3 3/16"	4"	1 1/2"
3(W/L)	3"	5 1/8"	6"	1 5/8"	3 3/16"	4 3/8"	1 1/2"
4(W/L)	3"	5 1/8"	6"	1 5/8"	3 1/4"	4 3/4"	1 1/2"
5(W/L)	3"	5 1/8"	6"	1 5/8"	3 1/4"	4 3/4"	1 1/2"
6(W/L)	5 1/4"	6 1/2"	7 3/4"	1 5/8"	4 7/8"	7 1/4"	1 1/2"

- GENERAL NOTES**
- SLATS/HOOD: SELECT FINISH OPTION BELOW:
- GALVANIZED ONLY
  - GRAY POLYESTER TOP COAT
  - WHITE POLYESTER TOP COAT
- OTHER SURFACES:
- SHOP COAT BLACK PRIMER
- OPERATION:
- RIGHT HAND SHOWN, LEFT HAND OPPOSITE
- GUIDES:
- STRUCTURAL STEEL ANGLES OF 3/16" MINIMUM THICKNESS
- BOTTOM BAR:
- TWO 2"x2"x1/8" STEEL ANGLES WITH PVC BULB ASTRAGAL
  - TWO 2"x1-1/2"x1/8" GALVANIZED ANGLES WITH PVC BULB ASTRAGAL

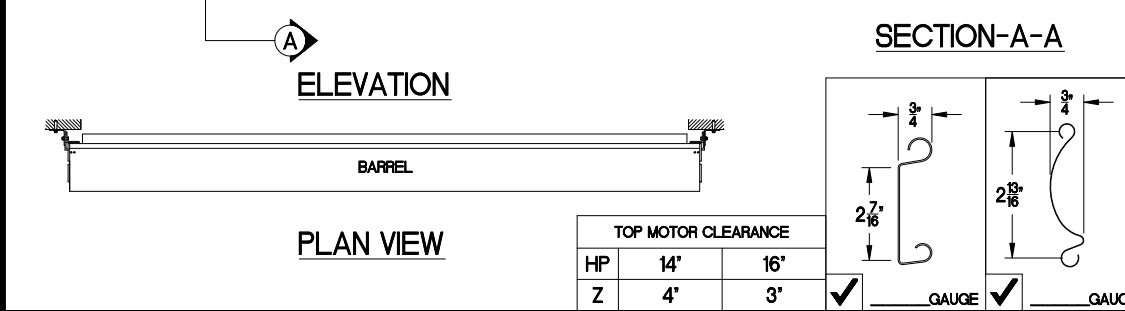

NOTE: ADD 'Z' TO 'X' TO ACHIEVE OVERALL HEADROOM REQUIREMENTS

MRK.	QTY.	OPENING SIZE		OPERATION	R.H.	CLEARANCES		OPTION	PROJECT:	DISTRIBUTOR:	DATE:	SHEET:	OF:	BY:	REF.#
		WIDTH 'W'	HEIGHT 'H'			L.H.	'X'+2'								

Asta Door Corporation is not responsible for the use of improper installation procedures, structural supports as well as field inspection prior to manufacturing and installation.

APPROVAL SIGNATURE: \_\_\_\_\_ DATE: \_\_\_\_\_

4255 McEver Industrial Dr.  
Acworth, GA 30101  
PH:(770) 924-2600  
Fax:(770) 974-1455  
www.astadoor.com

**400 SERIES -FACE OF WALL-WITH H MOTOR**