

GUIDE DIMENSIONS

GUIDE TYPE	A'	B'	C'	D'	E'	F'	G'
2	2. 5/8"	3. 7/8"	5. 1/8"	1. 1/4"	2. 13/16"	4"	1. 1/4"
3	2. 5/8"	4. 3/4"	5. 5/8"	1. 1/4"	2. 13/16"	4. 3/8"	1. 1/4"
4	2. 5/8"	4. 3/4"	5. 5/8"	1. 1/4"	2. 7/8"	4. 3/4"	1. 1/4"
2(W/L)	3"	4. 1/4"	5. 1/2"	1. 5/8"	3. 3/16"	4"	1. 1/2"
3(W/L)	3"	5. 1/8"	6"	1. 5/8"	3. 3/16"	4. 3/8"	1. 1/2"
4(W/L)	3"	5. 1/8"	6"	1. 5/8"	3. 1/4"	4. 3/4"	1. 1/2"
5(W/L)	3"	5. 1/8"	6"	1. 5/8"	3. 1/4"	4. 3/4"	1. 1/2"
6(W/L)	5. 1/4"	6. 1/2"	7. 3/4"	1. 5/8"	4. 7/8"	7. 1/4"	1. 1/2"

- GENERAL NOTES**
- SLATS/HOOD:** SELECT FINISH OPTION BELOW:
- GALVANIZED ONLY
 - GRAY POLYESTER TOP COAT
 - WHITE POLYESTER TOP COAT
- OTHER SURFACES:**
- SHOP COAT BLACK PRIMER
- OPERATION:**
- RIGHT HAND SHOWN, LEFT HAND OPPOSITE
- GUIDES:**
- STRUCTURAL STEEL ANGLES OF 3/16" MINIMUM THICKNESS
- BOTTOM BAR:**
- TWO 2"x2"x1/8" STEEL ANGLES WITH PVC BULB ASTRAGAL
 - TWO 2"x1-1/2"x1/8" GALVANIZED ANGLES WITH PVC BULB ASTRAGAL

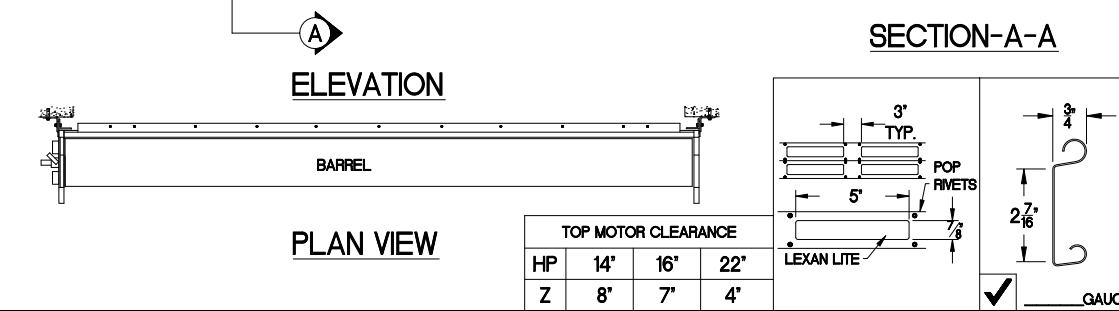

MRK.	QTY.	OPENING SIZE		OPERATION	R.H.	CLEARANCES		OPTION	PROJECT:	ARCHITECT:	CONTRACTOR:	DISTRIBUTOR:	DATE:	SHEET:	OF:	BY:	REF.#	400 SERIES-FACE OF WALL-VISION LITES-GH MOTOR
		WIDTH 'W'	HEIGHT 'H'			LH.	'X'+2'											

Asta Door Corporation is not responsible for the use of improper installation procedures, structural supports as well as field inspection prior to manufacturing and installation.

APPROVAL SIGNATURE: _____ DATE: _____

4255 McEver Industrial Dr.
Acworth, GA 30101
PH:(770) 924-2600
Fax:(770) 974-1455
www.astadoor.com