

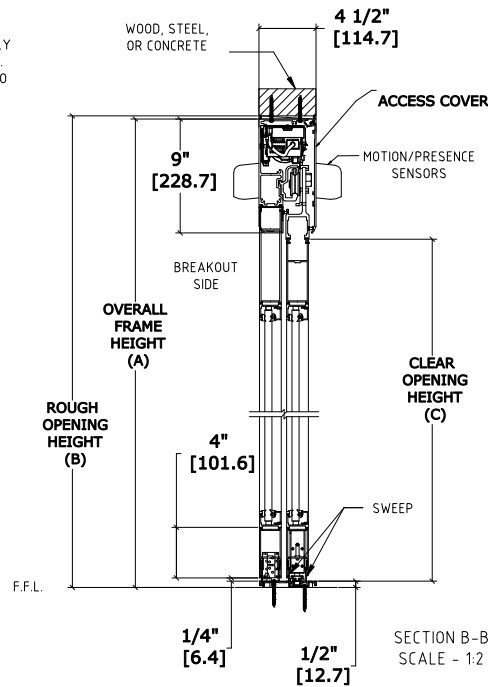

ASSA ABLOY ENTRANCE SYSTEMS
 1900 AIRPORT ROAD
 MONROE, NC 28110
 PHONE: 1-866-237-2687
 SPECDESK.NA.ENTRANCE@ASSAABLOY.COM

ASSA ABLOY SL500 Resilience R104

Overhead Concealed, Narrow Stile, Full Breakout, Bi-Part
 Large & Small Missile Impact - Level D

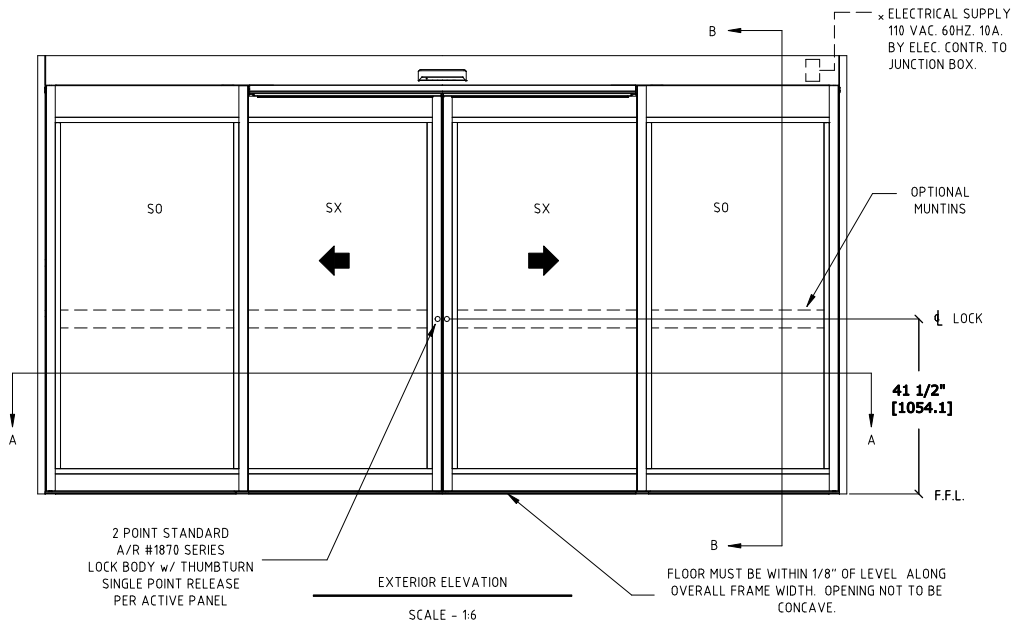

	OVERALL FRAME WIDTH (A)	ROUGH OPENING (B)	CLEAR OPENING (C)	DOOR WIDTH (D)	BREAKOUT WIDTH (E)
AT MAX WIDTH	192" [4876.8]	192 1/2" [4889.5]	81 5/8" [2060.6]	48 5/8" [1235.1]	175 9/16" [4459.3]
WIDTH FORMULA	B - 1/2" B - [12.7]	A + 1/2" A + [12.7]	A/2 - 13 7/8" A/2 - [352.4]	A/4 + 5/8" A/4 + [15.9]	A - 16 7/16" A - [417.5]
AT MAX HEIGHT	104" [2641.6]	104 1/4" [2648.0]	94" [2387.6]		
HEIGHT FORMULA	B - 1/4" B - [6.35]	A + 1/4" A + [6.35]	A - 10" A - [254.0]		

GLASS FORMULA: OFW /4 - 4 6/8 [120.7] X OFH -20 1/2 [520.70]

NOTES:

STANDARD PACKAGE CONSISTS OF:

- STANDARD FINISH:
 CLASS 1, .018MM, CLEAR- AA-M12C22A41
 CLASS 1, .018MM, DARK BRONZE- AA-M12C22A44
- AUTOMATIC OPERATOR
- NARROW STILE RAILS
- THRESHOLD
- 2-POINT LOCK WITH LOCK INDICATOR
- 9/16" GLASS STOPS AND BLOCKS
- 1/4" HS - .090" DUPONT SENTRYGLAS PLUS® - 1/4" HS
- DRY GLAZED
- MOTION/PRESENCE SENSORS
- 5-POSITION KNOB SWITCH
- BALL CATCH
- DUAL CONCEALED SWEEPS IN SX & SO PANELS
- 4" BOTTOM RAILS

OPTIONS AVAILABLE:

- SPECIAL FINISHES
- PANIC EXIT DEVICE
- 1" IG O.A. LAMINATED GLASS
- 3/8" HS - .090" DUPONT SENTRYGLAS PLUS® - 3/8" HS - 3/8" AIR GAP - 3/16" FT
- 7" /10" BOTTOM RAILS
- THRESHOLD LEAD-UP
- TRUE DIVIDED MUNTINS
- FALSE MUNTINS
- SEE SHEET OS-10 FOR ALL OTHER OPTIONS AND OPTION DETAILS

FOR MAXIMUM CURRENT DRAW, SEE PRODUCT SPECIFICATION,
 INSTALLATION INSTRUCTIONS, OR THE UL LABEL ON THE EQUIPMENT.

TEST PROTOCOLS: TAS 201, TAS 202 & TAS 203
 FLORIDA PRODUCT APPROVAL # FL30356

REFER TO RELEVANT [LOCAL, STATE, NATIONAL, OR AHJ]
 BUILDING CODE FOR MIN DOOR HEIGHT & MIN/MAX WIDTH
 ALLOWABLE FOR EGRESS REQUIREMENT IN CONJUNCTION
 WITH TABLE.

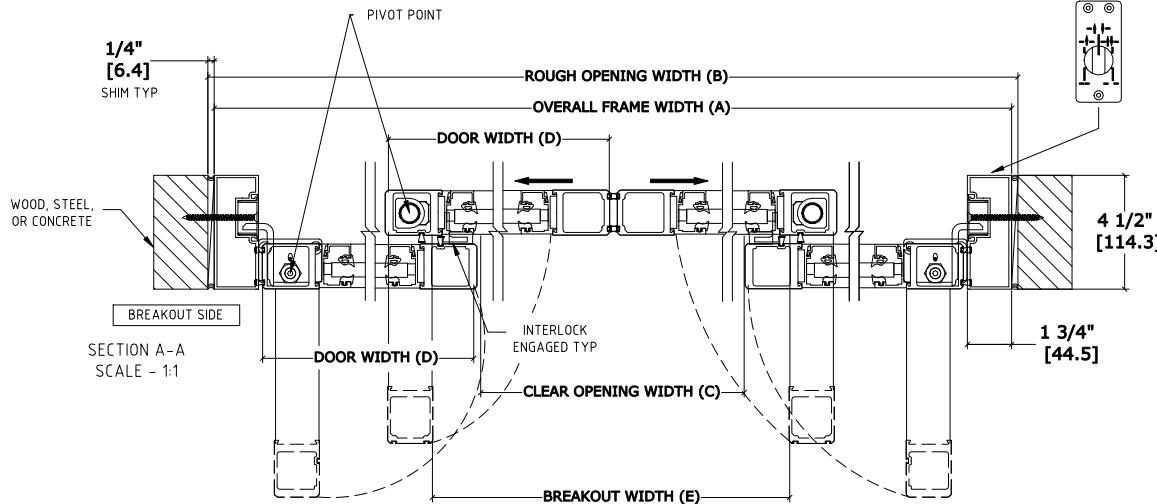

OPTIONAL FACTORY PREP
 FOR SWITCH LOCATION @
 74-1/2" H [1892.3]

DESIGN PRESSURE RATING	
WHERE WATER INFILTRATION REQUIREMENT IS NEEDED	WHERE WATER INFILTRATION REQUIREMENT IS NOT NEEDED
NOT APPROVED	+/- 80 PSF*

*PSF RATINGS RANGE FROM 80-115 PSF DEPENDENT ON PACKAGE WIDTH AND HEIGHT. FOR SPECIFIC RATINGS, CONSULT PRODUCT APPROVALS OR PSF/SIZE CALCULATOR ON THE PRODUCT WEBPAGE.

NOTE: PATENT PENDING

DWG NO.	1019913
DRN BY	SJF
DATE	9/18/19
CHK BY	
DATE	
REV.	2.0
DATE	10/17/19

