



Innovative Products

2395 West 4th Avenue Denver, CO 80223 USA  
 Phone 303.892.0400 Toll Free 800.333.4234 Fax 303.825.5988  
 EMail info@BisonIP.com Web www.BisonIP.com

Get CEU Credits, Details & Specifications online at [BisonIP.com](http://BisonIP.com)

**VERSADJUST**  
 Adjustable Deck Supports

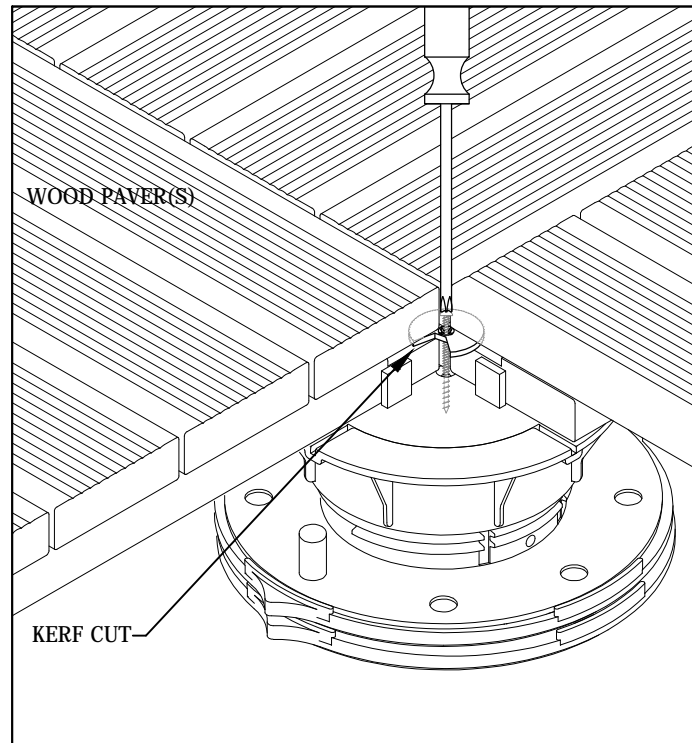

PLACE THE FS1 WASHER IN THE KERF CUT BETWEEN THE BOTTOM RAIL AND THE UPPER SLAT IN THE CORNERS OF THE THREE WOOD PAVERS. LEAVE THE NOTCH IN THE WASHER FACING OUTWARDS IN ORDER TO LEAVE ROOM TO PLACE THE 4th PAVER. AFTER ALL PAVERS ARE TIGHTLY IN PLACE, ROTATE THE WASHER USING A SCREWDRIVER SO THAT THE SOLID PART OF THE WASHER IS IN CONTACT WITH THE CORNERS OF ALL FOUR PAVERS. INSERT THE FS1 SCREW THROUGH THE HOLE IN THE CENTER OF THE WASHER AND THE PILOT HOLE IN THE CENTER OF THE TAB SET INTO THE TOP OF THE PEDESTAL. HAND TIGHTEN UNTIL THE CORNERS OF ALL FOUR PAVERS ARE SECURELY FASTENED TO THE PEDESTAL, DO NOT TO OVER-TIGHTEN.

MECHANICAL FASTENING KIT PATENT PENDING

GENERAL NOTES: APPLY TO ALL OF THE ABOVE PRODUCTS

1. INSTALLATION MUST BE COMPLETED IN ACCORDANCE WITH BISON INNOVATIVE PRODUCTS SPECIFICATIONS.
2. DRAWINGS NOT TO SCALE.
3. CONTRACTOR'S NOTE: FOR PRODUCT AND COMPANY INFORMATION VISIT [www.BisonIP.com](http://www.BisonIP.com)

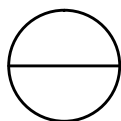

## FS1 FASTENING KIT

USING AN FS1 WITH BISON WOOD PAVERS