



Innovative Products

2395 West 4th Avenue Denver, CO 80223 USA
 Phone 303.892.0400 Toll Free 800.333.4234 Fax 303.825.5988
 EMail info@BisonIP.com Web www.BisonIP.com

VERSADJUST
Adjustable Deck Supports

BISON JOIST TOP DETAILS WITH BISON 2X2 TILES

GENERAL NOTES

1. FIRST MECHANICALLY FASTEN JOIST TOP TO TOP OF PEDESTAL USING BISON PROVIDED SCREW.
2. WOOD JOISTS OR BEAMS ARE INSTALLED ON TOP OF THE PEDESTALS.
3. FOLD FLAPS AROUND JOIST OR BEAM AND MECHANICALLY FASTEN WITH WOOD SCREWS.

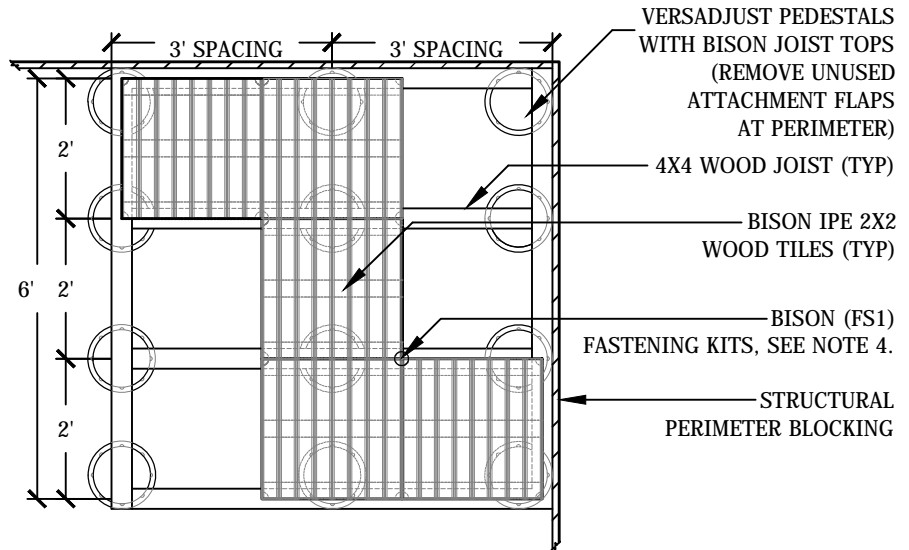

TWO WAY BEAM DETAIL- SAMPLE BISON JOIST TOPS WITH IPE TILE LAYOUT

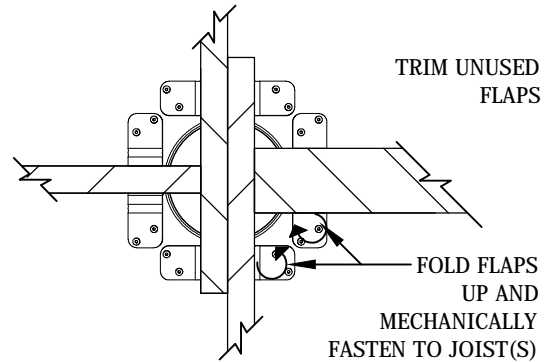
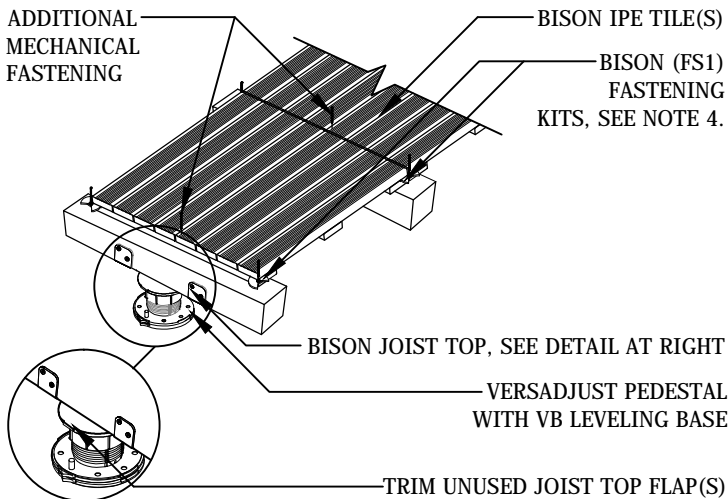

BISON JOIST TOP ACCOMMODATES NOMINAL WIDTH SIZED 2X AND 4X4 LUMBER.

BISON WOOD TILES TO JOIST DETAIL

TYPICAL JOIST TOP WITH LUMBER VIEW

GENERAL NOTES: APPLY TO ALL OF THE ABOVE PRODUCTS

1. INSTALLATION MUST BE COMPLETED IN ACCORDANCE WITH BISON INNOVATIVE PRODUCTS SPECIFICATIONS.
2. DRAWINGS NOT TO SCALE.
3. CONTRACTOR'S NOTE: FOR PRODUCT AND COMPANY INFORMATION VISIT www.BisonIP.com
4. MECHANICAL FASTENING KITS (FS1) ARE INSTALLED AT BISON TILE CORNERS.

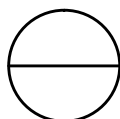

JOIST TOP AND TILES

SAMPLE JOIST AND WOOD TILE LAYOUT