

PART NUMBER:
SVR303

PART NUMBER:
SVR303
JOB NUMBER:
NA

A

BLUE GIANT EQUIPMENT CORP.

85 Heart Lake Road South
Brampton, Ontario, L6W 3K2
Tel: 905-457-3900
Fax: 905-457-5586



PROPRIETARY AND CONFIDENTIAL

THE INFORMATION CONTAINED IN THIS DRAWING IS THE SOLE PROPERTY OF BLUE GIANT EQUIPMENT CORPORATION. ANY REPRODUCTION IN PART OR AS A WHOLE WITHOUT THE WRITTEN PERMISSION OF BLUE GIANT EQUIPMENT CORPORATION IS PROHIBITED.

DIMENSIONS ARE IN INCHES
TOLERANCES:
FRACTIONAL 1/32
ANGULAR: MACH 5 BEND 2
ONE PLACE DECIMAL 0.015
TWO PLACE DECIMAL 0.010
THREE PLACE DECIMAL 0.005

THIRD ANGLE PROJECTION

DESCRIPTION
SVR303 GENERAL ASSY

DWG. NO. SVR303

FOR: SVR303

REF.

APPROX. WEIGHT (lb.): 261.989 LBS

SCALE: 1:12 SIZE A

MATERIAL

MATERIAL NO

	NAME	SIGNATURE	DATE
DRAWN	BA		May 06, 2009
DESIGN	CL		May 06, 2009
ENG APPR.	GB		May 06, 2009
MFG APPR.	DL		May 06, 2009
Q.A.	TP		May 06, 2009

COATING:
ZINC COATING

FINISH:
AS IS

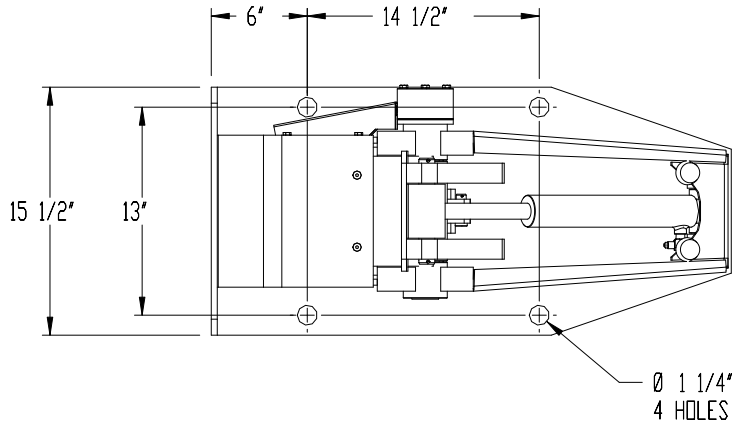

AFTER APPROVAL PLEASE
RETURN THIS DRAWING TO:
BLUE GIANT EQUIP. CORP.

