

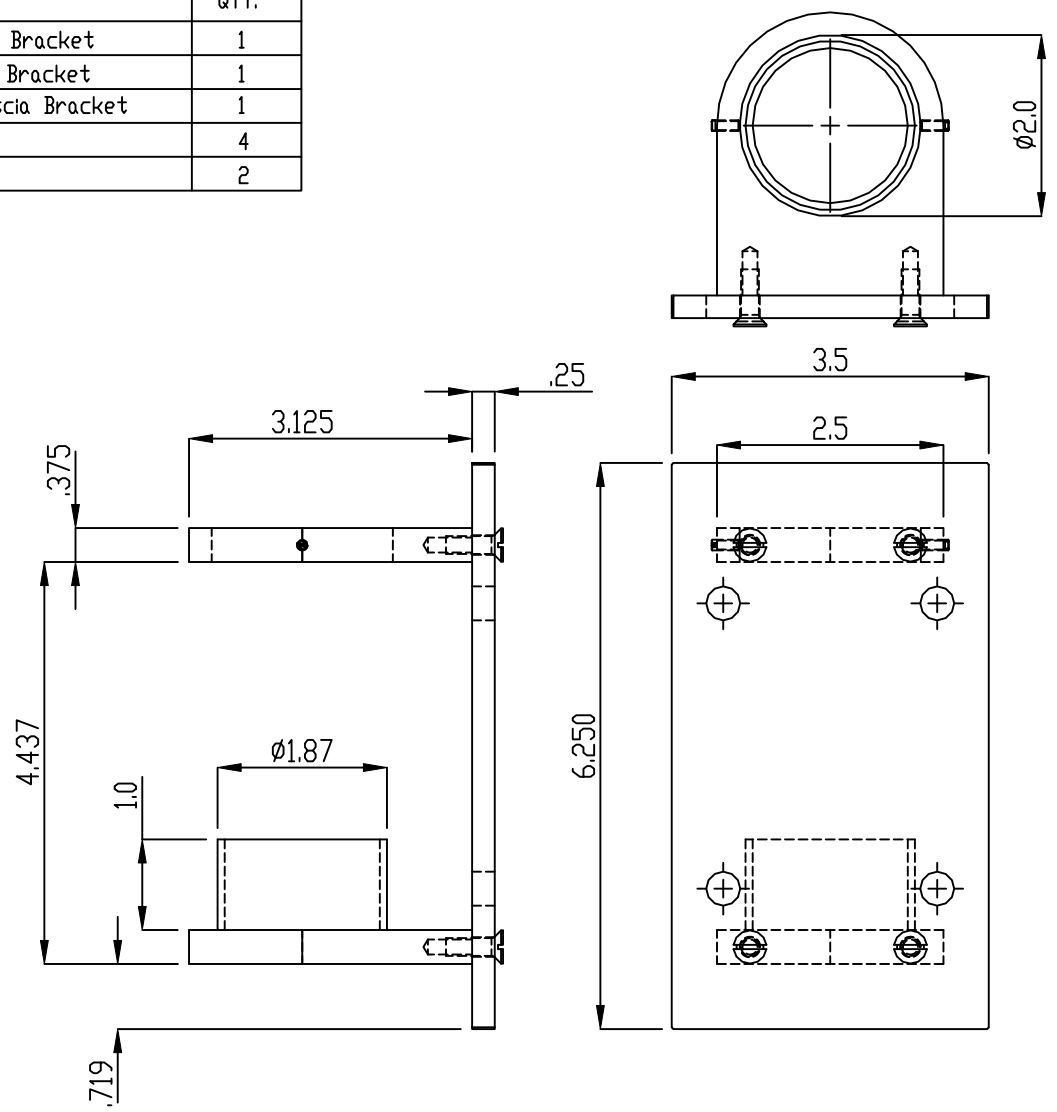

ITEM NO.	PART NUMBER	DESCRIPTION	QTY.
1	05-310-01	Plate-Stainless 2' Fascia Bracket	1
2	05-310-02	Base-Stainless 2' Fascia Bracket	1
3	05-310-03	Retainer Ring-Stainless 2' Fascia Bracket	1
4	M5 x 0.8 x 16MM FHSCS	STD	4
5	M3 x 0.5 x 5MM SET SCREW	STD	2

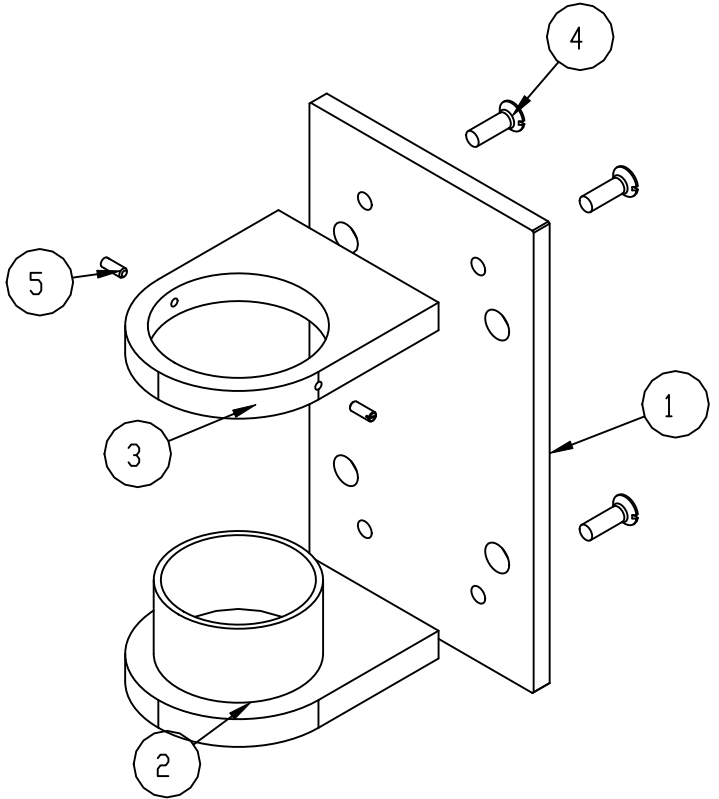

ALL DIMENSIONS ARE IN INCHES

REV	DATE	DESCRIPTION OF CHANGE	ECN	BY.	APPR
REVISIONS					
		TOLERANCES XX ±.01 UNLESS OTHERWISE SPECIFIED XXX ±.005 ANGULAR ±0.5° FRACTIONAL ±1/32	THIS DRAWING IS THE PROPERTY OF STAINLESS CABLE & RAILING AND IS PROTECTED UNDER COPYRIGHT LAW AS AN UNPUBLISHED WORK. IT MAY NOT BE PUBLISHED, COPIED OR REPRODUCED WITHOUT EXPRESS WRITTEN PERMISSION FROM SC&R		
DRAWN BY.		DATE	PROJECT	TITLE : Stainless Fascia Bracket Assm DRG NO. 05-310-00-ASM	
				SHEET 1 OF 1	