

ITEM NO.	PART NUMBER	DESCRIPTION	QTY.	MATERIAL TYPE
1	05-230-01	Base - Stainless 2" 90° Post Cap	1	316 SS
2	05-220-02	Cup - Stainless 2" 90° Post Cap (Radius Saddle)	1	316 SS
3		M6 x 1.0 x 20mm FHSCS	1	

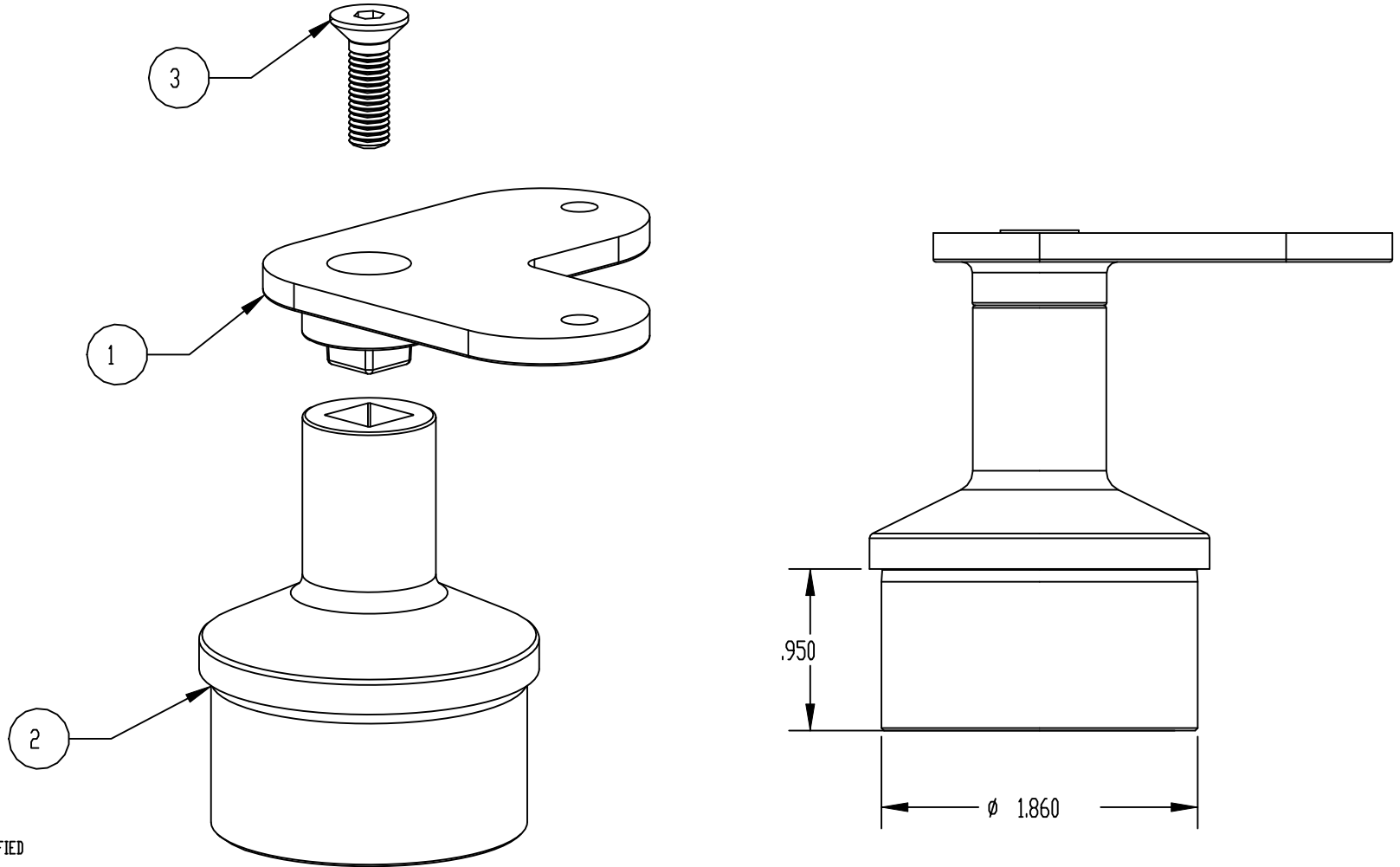

- NOTES:** UNLESS OTHERWISE SPECIFIED
- DIMENSIONS ARE IN INCHES (MM).
  - MACHINED SURFACES TO BE 63 ?IN MAX.
  - DO NOT SCALE DRAWING.
  - PART TO BE FREE OF BURRS AND SHARP EDGES.
  - ALL MATERIAL TO BE CLEAN, DEGREASED AND FREE OF ALL IMPURITIES.
  - ANY CHANGE MUST BE AUTHORIZED BY AN SC&R ENGINEER.

MATERIAL TYPE: See BOM

VENDOR ID:

REV	DATE	DESCRIPTION OF CHANGE	ECN	BY	APPR
REVISIONS					
		TOLERANCES UNLESS OTHERWISE SPECIFIED .XX ±.01 .XXX ±.005 ANGULAR ±0.5° FRACTIONAL #1/32	THIS DRAWING IS THE PROPERTY OF STAINLESS CABLE & RAILING AND IS PROTECTED UNDER COPYRIGHT LAW AS AN UNPUBLISHED WORK. IT MAY NOT BE PUBLISHED, COPIED OR REPRODUCED WITHOUT EXPRESS WRITTEN PERMISSION FROM SC&R.		TITLE Stainless 2" 90° Post Cap ASM (Flat Saddle)
DRAWN BY GM		DATE 1/10/2011	PROJECT 05-230-00-ASM		SHEET 1 OF 1