

2

1

B

B

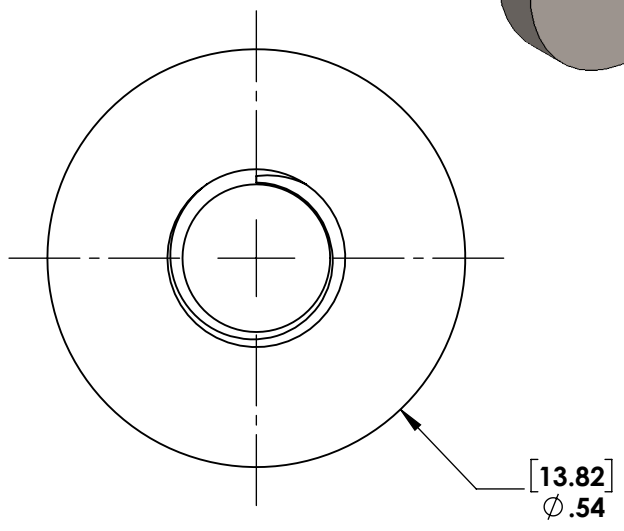
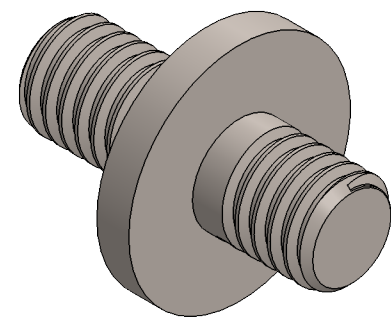
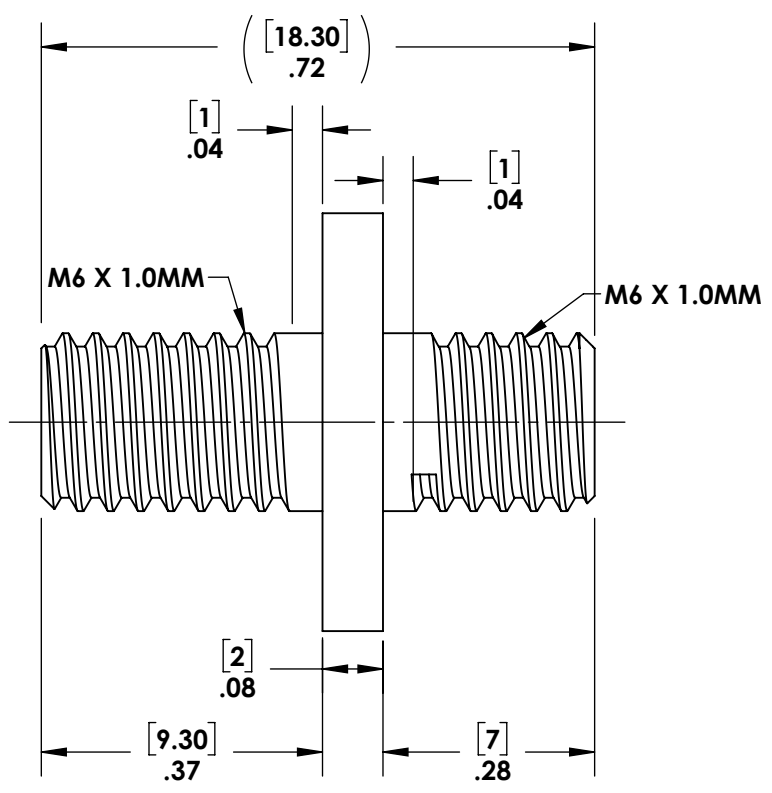

A

A



PROPRIETARY AND CONFIDENTIAL

THE INFORMATION CONTAINED IN THIS DRAWING IS THE SOLE PROPERTY OF STAINLESS CABLE AND RAILING®. ANY REPRODUCTION IN PART OR AS A WHOLE WITHOUT THE WRITTEN PERMISSION OF STAINLESS CABLE AND RAILING® IS PROHIBITED.

NOTES: UNLESS OTHERWISE SPECIFIED		NAME	DATE	TITLE:	
1. DUAL DIMENSIONS SHOWN - INCHES [MM]. 2. MACHINED SURFACES TO BE 63uIN MAX. 3. PART TO BE FREE OF BURRS AND SHARP EDGES. 4. ALL MATERIAL TO BE CLEAN, DEGREASED AND FREE OF ALL IMPURITIES. 5. ANY CHANGE MUST BE AUTHORIZED BY AN SC&R ENGINEER.	DIMENSIONS ARE IN INCHES	SCR	09/29/17	<b>CABLE QUICK NUT CONNECTOR</b>	
	FRACTIONAL ±				
	ANGULAR: MACH ±				
	TWO PLACE DECIMAL ±				
	THREE PLACE DECIMAL ±				
MATERIAL	316 SS	COMMENTS:		SIZE	DWG. NO.
FINISH				<b>A</b>	<b>01-031-01A</b>
				SCALE: 4:1	WEIGHT:
				SHEET 1 OF 1	

2

1