

4

3

2

1

D

D

C

C

B

B

A

A

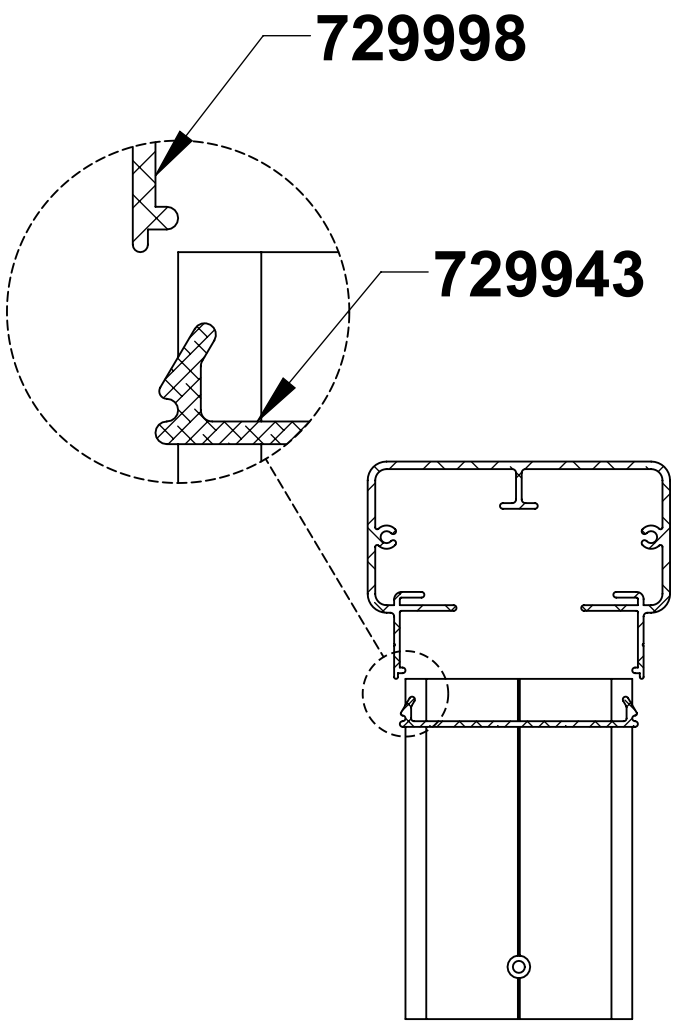
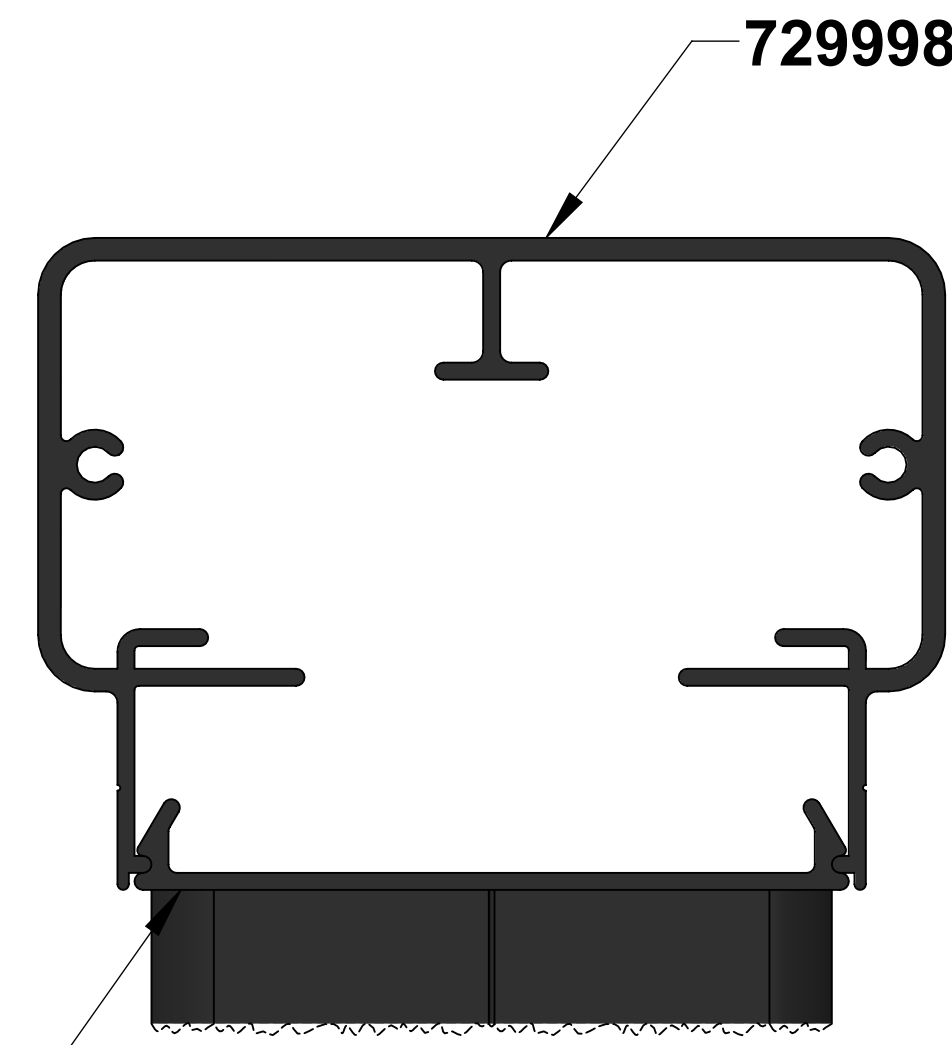
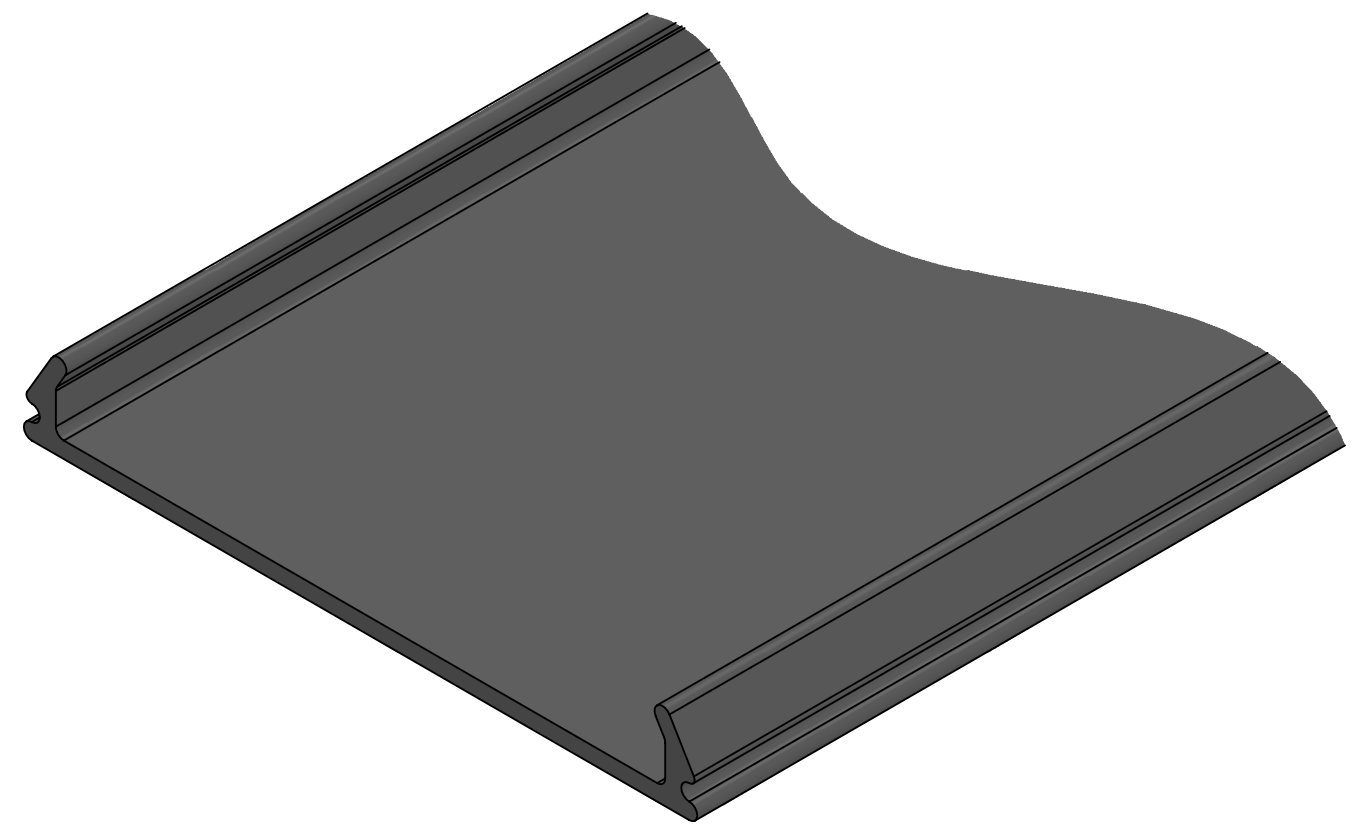
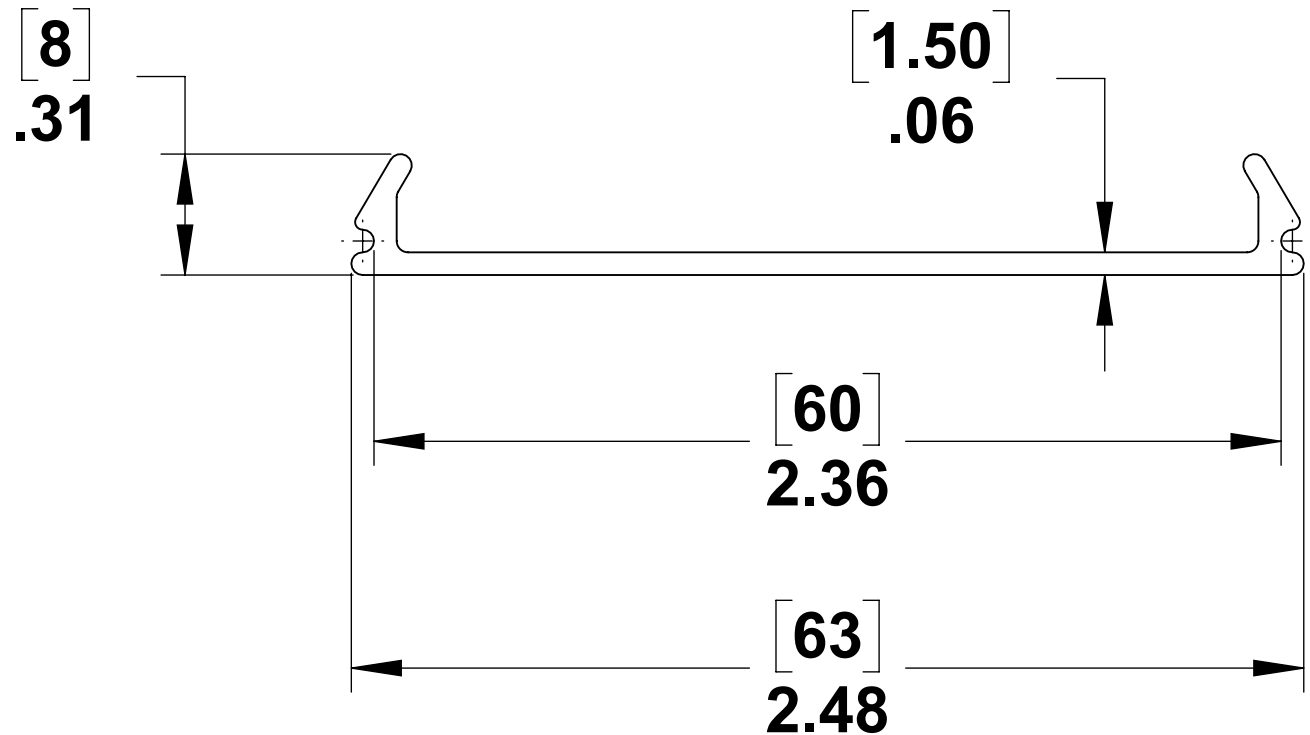

SECTION A-A

DURING INSTALLATION

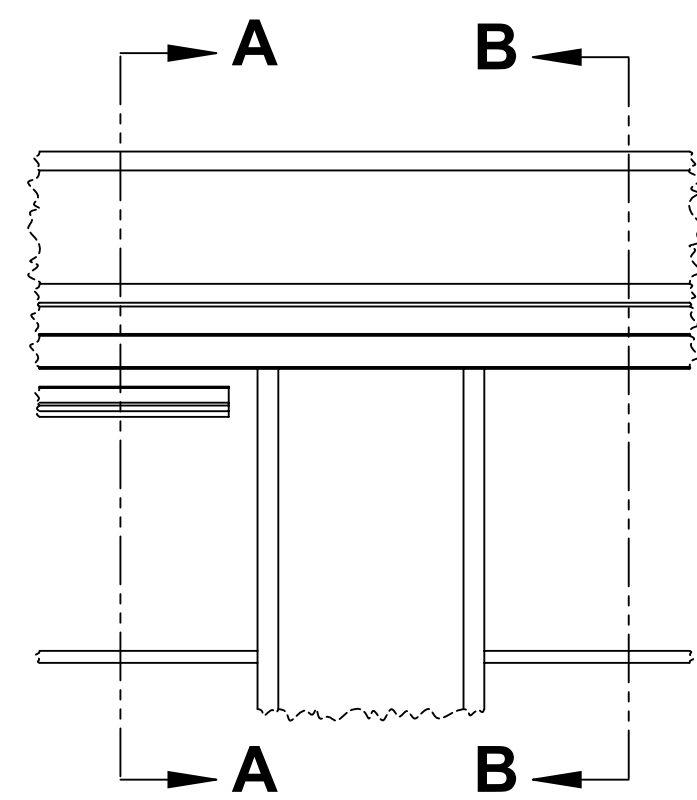

SCALE 1 : 2

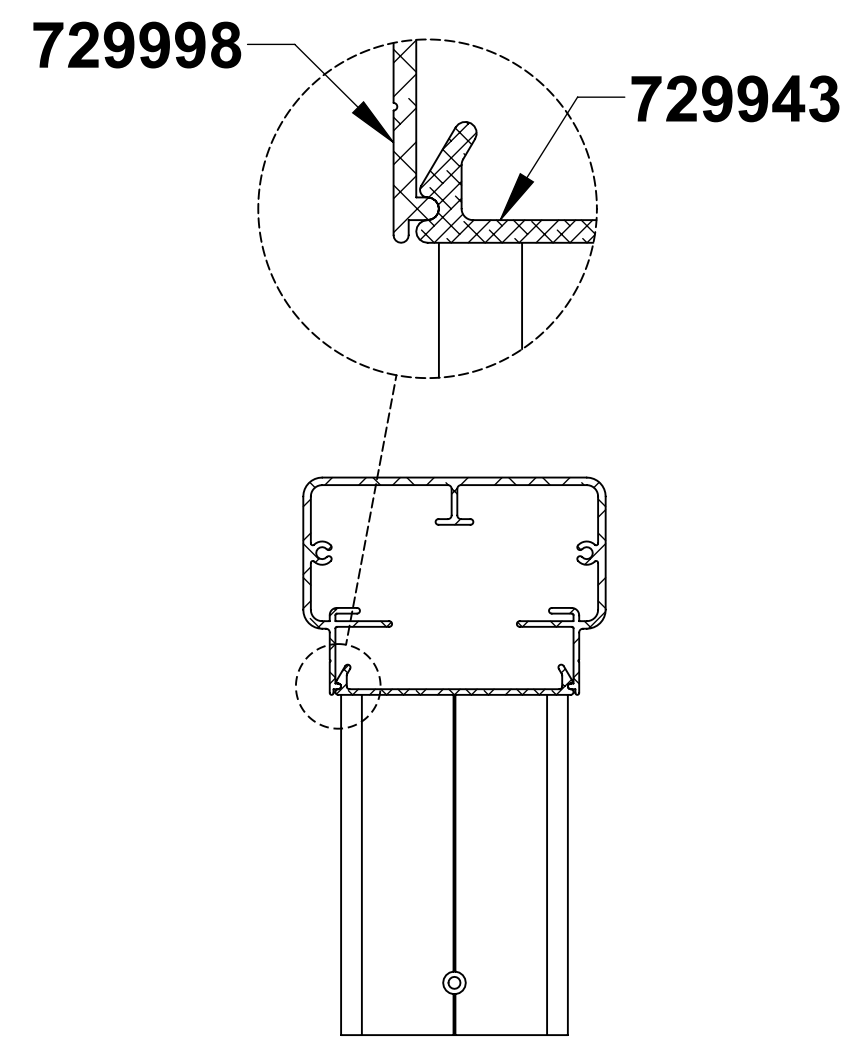

SECTION B-B

AFTER INSTALLATION

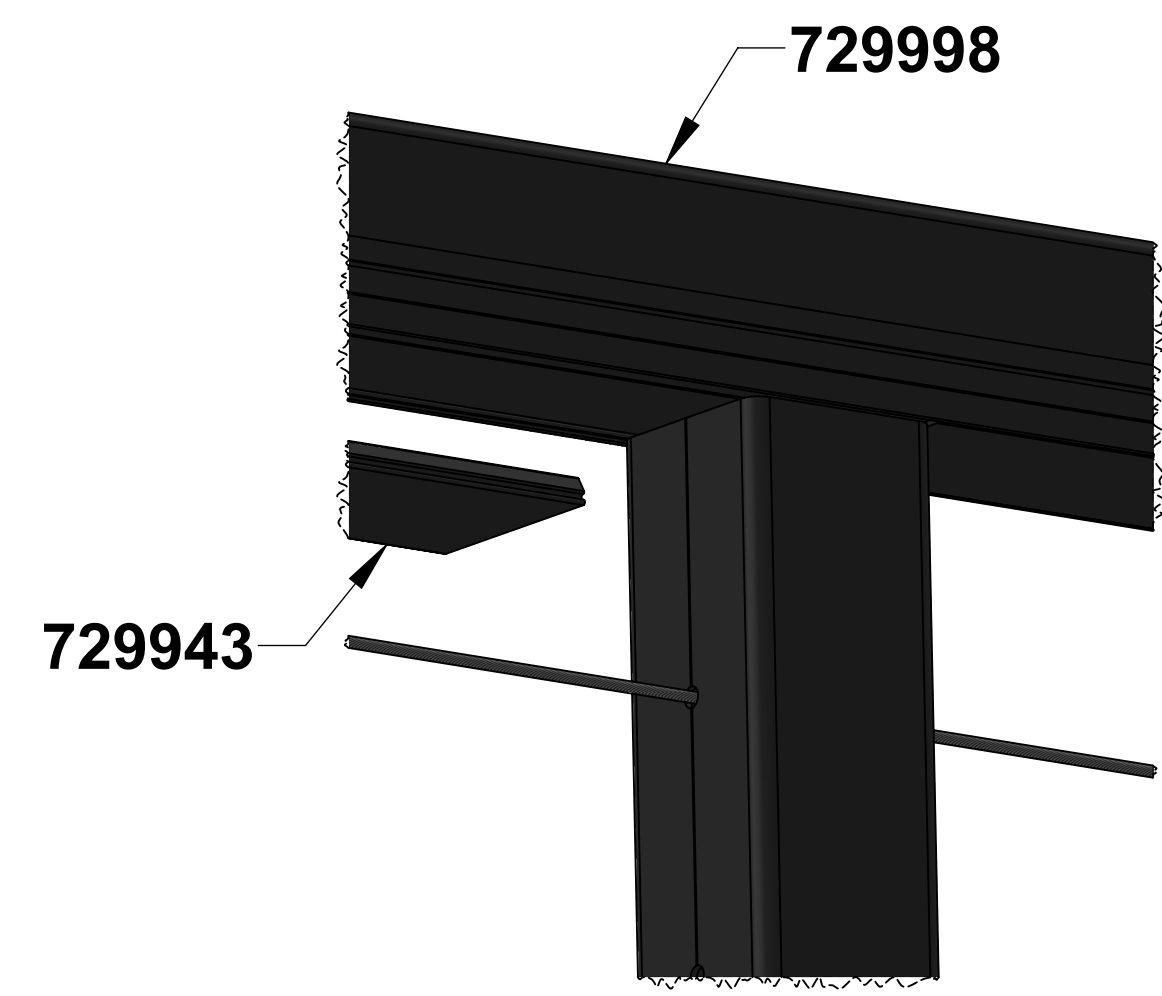

729943 INSTALLATION



PROPRIETARY AND CONFIDENTIAL
 THE INFORMATION CONTAINED IN THIS DRAWING IS THE SOLE PROPERTY OF STAINLESS CABLE AND RAILING. ANY REPRODUCTION IN PART OR AS A WHOLE WITHOUT THE WRITTEN PERMISSION OF STAINLESS CABLE AND RAILING IS PROHIBITED.

NOTES: UNLESS OTHERWISE SPECIFIED	
1. DUAL DIMENSIONS SHOWN - INCHES [MM].	DIMENSIONS ARE IN INCHES
2. MACHINED SURFACES TO BE 63µIN MAX.	FRACTIONAL ±
3. PART TO BE FREE OF BURRS AND SHARP EDGES.	ANGULAR: MACH ±
4. ALL MATERIAL TO BE CLEAN, DEGREASED AND FREE OF ALL IMPURITIES.	TWO PLACE DECIMAL ±
5. ANY CHANGE MUST BE AUTHORIZED BY AN SC&R ENGINEER.	THREE PLACE DECIMAL ±
MATERIAL	6082 T6 ALU
FINISH	

NAME	DATE
SCR	10/23/17
ENG APPR.	
MFG APPR.	

COMMENTS:
 POWDERCOATING TO MEET OR EXCEED AAMA2604 SALT SPRAY RESISTANCE

TITLE: TOP RAIL SNAP COVER		
SIZE C	DWG. NO. 729943	REV 01
SCALE: 2:1	WEIGHT:	SHEET 1 OF 1

4

3

2

1