

2

1

B

B

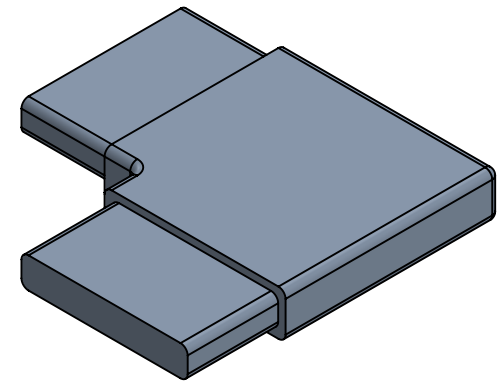
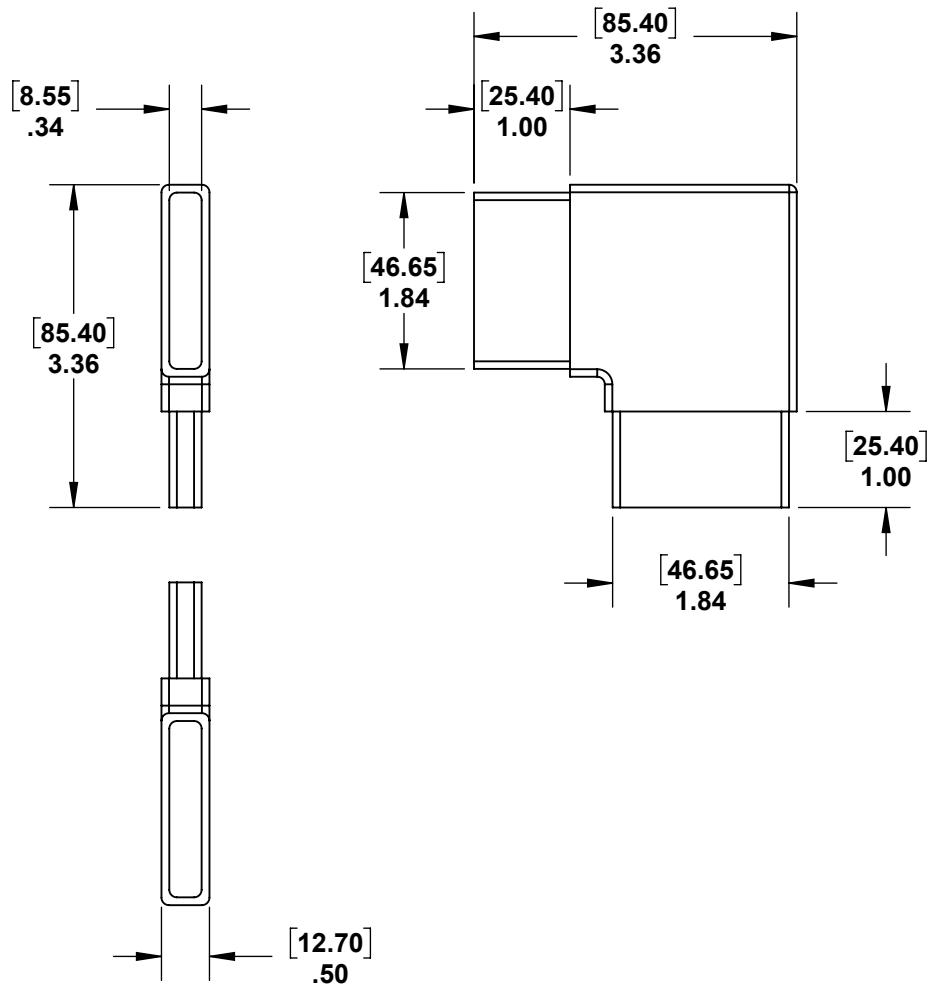

A

A



PROPRIETARY AND CONFIDENTIAL

THE INFORMATION CONTAINED IN THIS DRAWING IS THE SOLE PROPERTY OF STAINLESS CABLE AND RAILING®. ANY REPRODUCTION IN PART OR AS A WHOLE WITHOUT THE WRITTEN PERMISSION OF STAINLESS CABLE AND RAILING® IS PROHIBITED.

NOTES: UNLESS OTHERWISE SPECIFIED

- 1. DIMENSIONS SHOWN - INCHES [MM].
- 2. MACHINED SURFACES TO BE 63µIN MAX.
- 3. PART TO BE FREE OF BURRS AND SHARP EDGES.
- 4. ALL MATERIAL TO BE CLEAN, DEGREASED AND FREE OF ALL IMPURITIES.
- 5. ANY CHANGE MUST BE AUTHORIZED BY AN SC&R ENGINEER.

|                          |        |
|--------------------------|--------|
| DIMENSIONS ARE IN INCHES |        |
| FRACTIONAL               | ±      |
| ANGULAR: MACH            | ±      |
| TWO PLACE DECIMAL        | ±      |
| THREE PLACE DECIMAL      | ±      |
| MATERIAL                 | 316 SS |
| FINISH                   |        |

|           |      |          |
|-----------|------|----------|
|           | NAME | DATE     |
| DRAWN     | SCR  | 02/28/18 |
| ENG APPR. |      |          |
| MFG APPR. |      |          |
| COMMENTS: |      |          |

|   |               |              |
|---|---------------|--------------|
| TITLE: <b>FLAT STAINLESS STEEL TOP RAIL 90° ELBOW</b> |               |              |
| SIZE  | DWG. NO.      | REV          |
| <b>A</b>  | <b>734442</b> | <b>01</b>    |
| SCALE: 1:2  | WEIGHT:       | SHEET 1 OF 1 |

2

1