

2

1

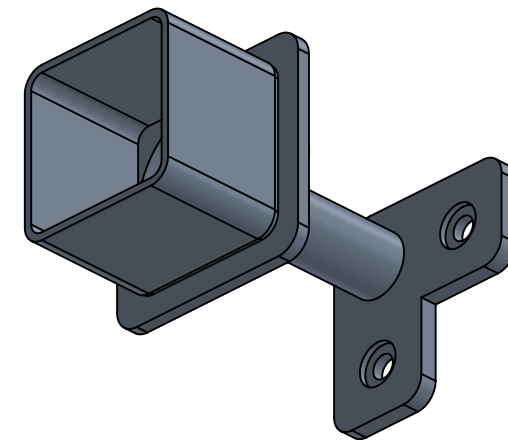
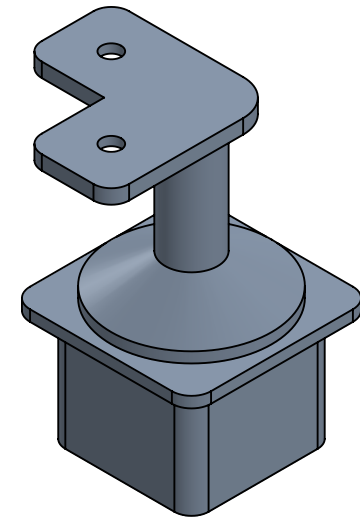
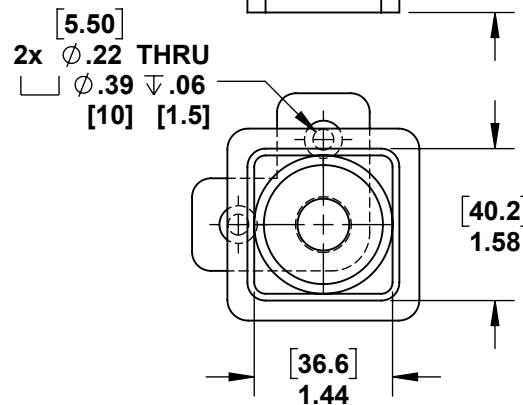
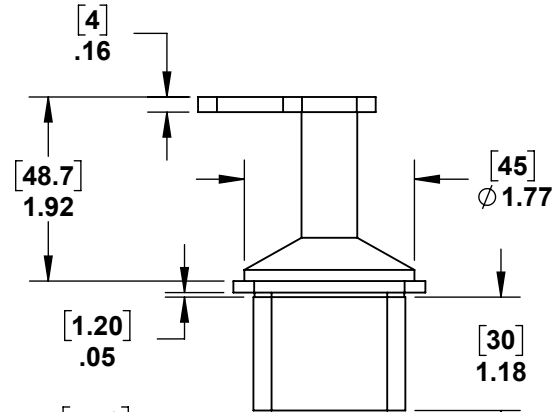
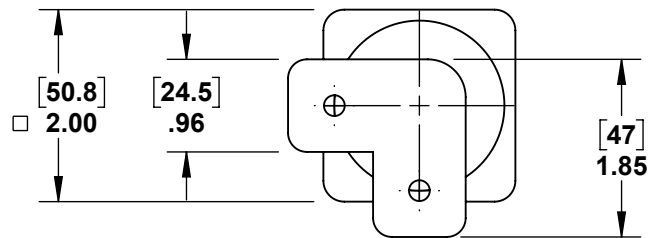

B

B

A

A



PROPRIETARY AND CONFIDENTIAL

THE INFORMATION CONTAINED IN THIS DRAWING IS THE SOLE PROPERTY OF STAINLESS CABLE AND RAILING®. ANY REPRODUCTION IN PART OR AS A WHOLE WITHOUT THE WRITTEN PERMISSION OF STAINLESS CABLE AND RAILING® IS PROHIBITED.

NOTES: UNLESS OTHERWISE SPECIFIED

1. DIMENSIONS SHOWN - INCHES [MM].
2. MACHINED SURFACES TO BE 63µIN MAX.
3. PART TO BE FREE OF BURRS AND SHARP EDGES.
4. ALL MATERIAL TO BE CLEAN, DEGREASED AND FREE OF ALL IMPURITIES.
5. ANY CHANGE MUST BE AUTHORIZED BY AN SC&R ENGINEER.

DIMENSIONS ARE IN INCHES  
 FRACTIONAL ±  
 ANGULAR: MACH ±  
 TWO PLACE DECIMAL ±  
 THREE PLACE DECIMAL ±

MATERIAL 316 SS

FINISH

NAME DATE

DRAWN SCR 03/27/18

ENG APPR.

MFG APPR.

COMMENTS:

TITLE: **STAINLESS SQUARE CORNER FLAT POST CAP**

SIZE <b>A</b>	DWG. NO. <b>982819</b>	REV <b>01</b>
------------------	---------------------------	------------------

SCALE: 1:2	WEIGHT:	SHEET 1 OF 1
------------	---------	--------------

2

1