

2

1

B

B

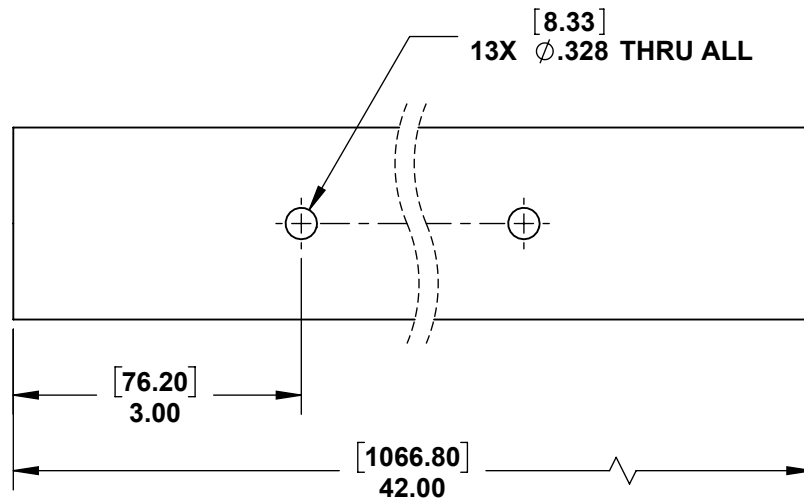
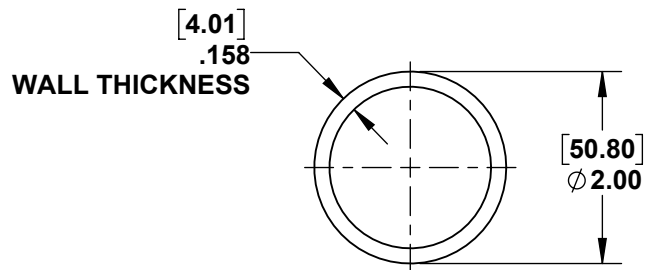
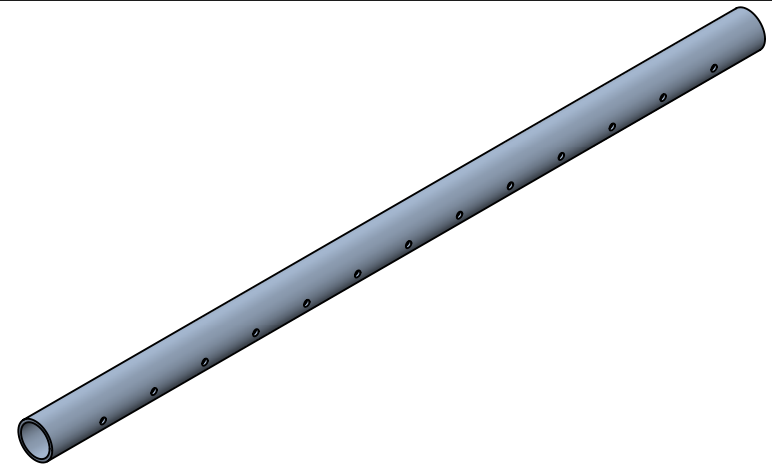

A

A



PROPRIETARY AND CONFIDENTIAL

THE INFORMATION CONTAINED IN THIS DRAWING IS THE SOLE PROPERTY OF STAINLESS CABLE AND RAILING®. ANY REPRODUCTION IN PART OR AS A WHOLE WITHOUT THE WRITTEN PERMISSION OF STAINLESS CABLE AND RAILING® IS PROHIBITED.

NOTES: UNLESS OTHERWISE SPECIFIED		NAME	DATE	TITLE:	
1. DIMENSIONS SHOWN - INCHES [MM]. 2. MACHINED SURFACES TO BE 63µIN MAX. 3. PART TO BE FREE OF BURRS AND SHARP EDGES. 4. ALL MATERIAL TO BE CLEAN, DEGREASED AND FREE OF ALL IMPURITIES. 5. ANY CHANGE MUST BE AUTHORIZED BY AN SC&R ENGINEER.	DIMENSIONS ARE IN INCHES	DRAWN	SCR	ROUND TERMINAL STAINLESS STEEL DECK MOUNT 42" POST	
	FRACTIONAL ±	ENG APPR.		SIZE	DWG. NO.
	ANGULAR: MACH ±	MFG APPR.		A	988682
	TWO PLACE DECIMAL ±	COMMENTS:		REV	01
	THREE PLACE DECIMAL ±			SCALE: 1:2	WEIGHT:
MATERIAL	316 SS				
FINISH					
DO NOT SCALE DRAWING					

2

1