

2

1

B

B

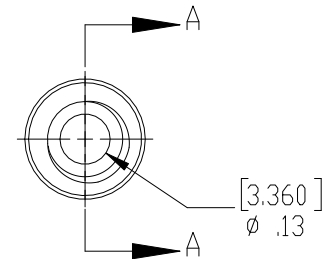
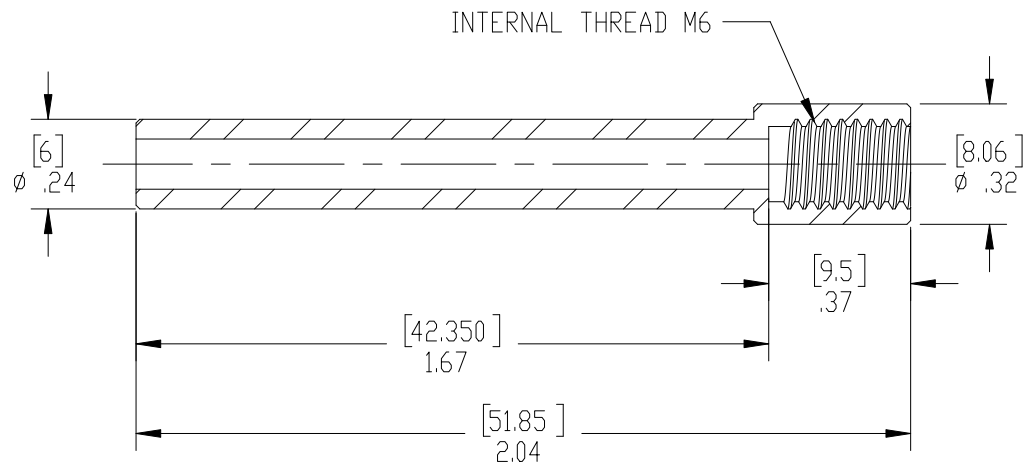
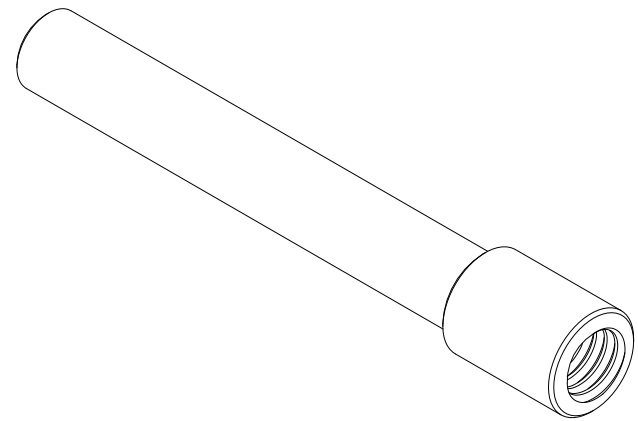

SECTION A-A

A

A



PROPRIETARY AND CONFIDENTIAL

THE INFORMATION CONTAINED IN THIS DRAWING IS THE SOLE PROPERTY OF STAINLESS CABLE AND RAILING. ANY REPRODUCTION IN PART OR AS A WHOLE WITHOUT THE WRITTEN PERMISSION OF STAINLESS CABLE AND RAILING IS PROHIBITED.

NOTES: UNLESS OTHERWISE SPECIFIED

1. DUAL DIMENSIONS SHOWN - INCHES [MM].
2. MACHINED SURFACES TO BE 63μIN MAX.
3. PART TO BE FREE OF BURRS AND SHARP EDGES.
4. ALL MATERIAL TO BE CLEAN, DEGREASED AND FREE OF ALL IMPURITIES.
5. ANY CHANGE MUST BE AUTHORIZED BY AN SC&R ENGINEER.

DIMENSIONS ARE IN INCHES
 FRACTIONAL ±
 ANGULAR: MACH ±
 TWO PLACE DECIMAL ±
 THREE PLACE DECIMAL ±

MATERIAL
 316 SS

FINISH

NAME	SCR	DATE	09/29/17
DRAWN			
ENG APPR.			
MFG APPR.			

COMMENTS:

TITLE: CABLE QUICK TERMINAL		
SIZE A	DWG. NO. 01-041-01A	REV 01
SCALE: 2:1	WEIGHT:	SHEET 1 OF 1

2

1