

CAUTION

DETAIL NOT FOR USE ON 25 OR 30-YEAR WARRANTY PROJECTS OR WHEN USING 90-MIL MEMBRANE. ACCEPTABLE EDGING SHALL CONFORM TO THERMOSET UNIVERSAL DETAILS U-1A.1, U-1C, U-1D OR U-1E.

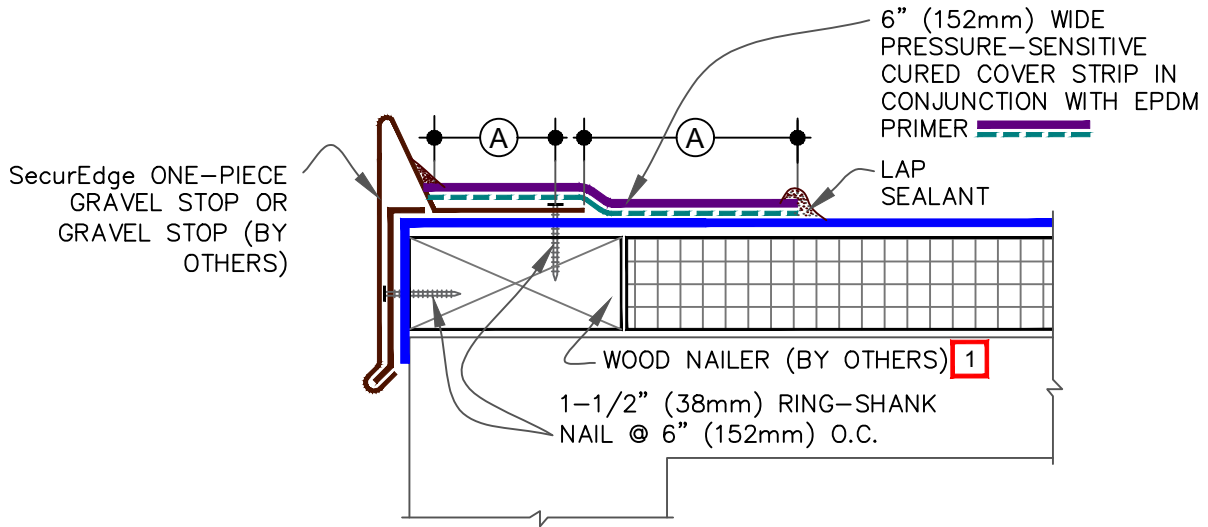



NOTES:

1. WOOD NAILER MUST EXTEND PAST TOTAL WIDTH OF GRAVEL STOP.
2. TO REMOVE FINISHING OILS, SCRUB METAL FLANGE WITH WEATHERED MEMBRANE CLEANER; ALLOW TO DRY PRIOR TO APPLYING PRIMER.
3. LAP SEALANT MUST BE APPLIED AT FLASHING OVERLAPS AND INTERSECTIONS WITH JOINTS IN METAL EDGING.
4. APPLY LAP SEALANT ALONG THE LEADING EDGE OF THE MEMBRANE SPLICE (UNDER THE 6"X6" T-JOINT COVER) COVERING THE EXPOSED SPLICE TAPE 1/2" (13mm) IN ALL DIRECTIONS FROM THE SPLICE INTERSECTION.
5. REFER TO APPLICABLE [CARLISLE METAL EDGING INSTRUCTION MANUAL](#) FOR STEP-BY-STEP INSTALLATION PROCEDURES.

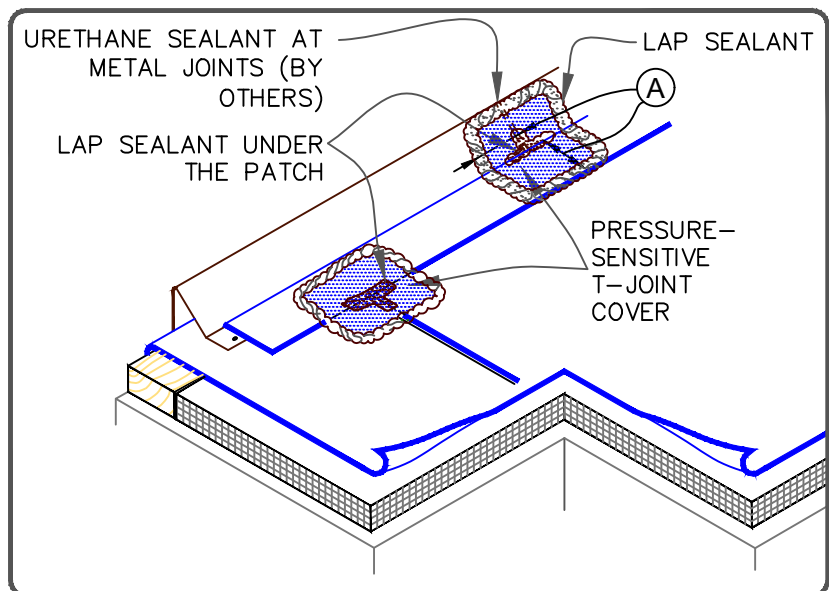
DIMENSION	mm	
(A) 2"	51	MIN.

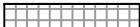

 —• EPDM  —• APPROVED SUBSTRATE  —• SEE NOTE(S)	SecurEdge ONE-PIECE GRAVEL STOP		DETAIL NO. U-1B
For additional information, refer to Specifications		THERMOSET UNIVERSAL	