

Alternate overlap

Cut back edge of shingle or shakes on bevel.
Join ridge material with type 304 or 316 stainless steel fasteners
See fastener details

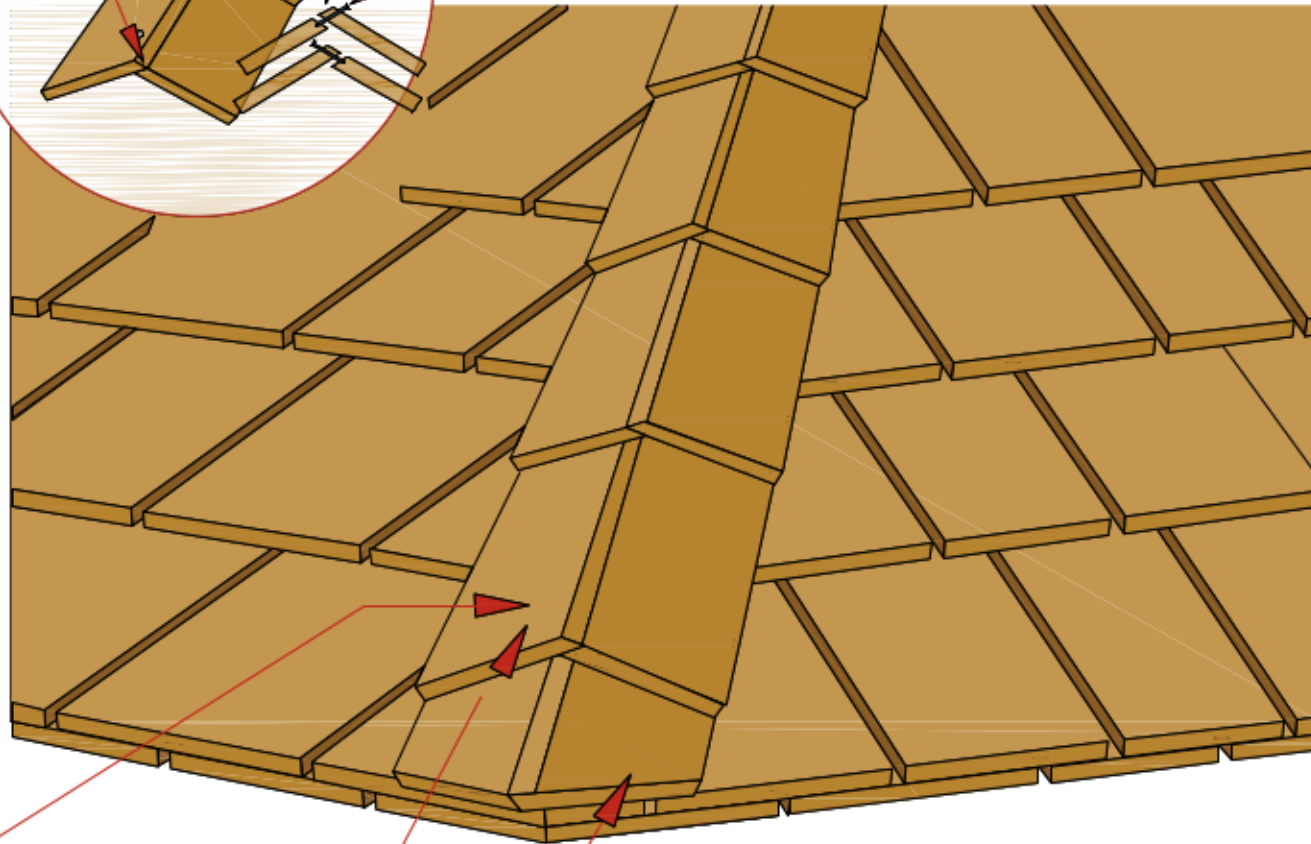

Position fasteners approximately 2" above exposure line

Double starter course

Choose material of uniform width between 4" and 5"
(if making units with field material)

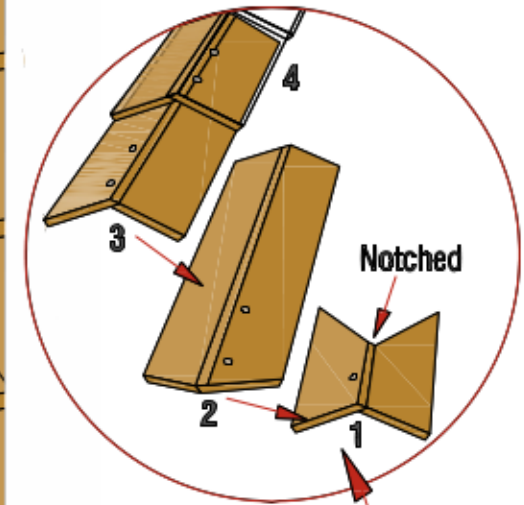

Notched

Notch first piece of starter course

Figure 8: Certi-label® Hip and Ridge Application